



**MASTERWALL.**

## **M-SERIES**

**BAL 29, lightweight, reinforced, external insulating wall system incorporating pre-coated panel.**

TECHNICAL DOCUMENT:

### **SYSTEM INSTALLATION & CONSTRUCTION DETAILS DIRECT-TO-FRAME SYSTEM**

MASTERWALL AUSTRALIA PTY LTD. 18-20 Cyber Loop, Dandenong South, Victoria, Australia  
EMAIL. [sales@masterwall.com.au](mailto:sales@masterwall.com.au) WEB. [masterwall.com.au](http://masterwall.com.au) NATIONAL ENQUIRIES. (03) 9799 6565 FAX. (03) 8740 2180

**POLYURETHANE FOAM SEALANT:**

100% flexibility ensures integrity and weatherproofing of joints.

**MESHED & PRIMED MASTERWALL PANELS:**

M grade polystyrene, light weight, designed to move with the frame

**FIXINGS:**

Pre-assembled 50mm button and class 4 screw sets provide the right fix for every situation.

**ALLOY EXTERNAL CORNERS:**

With integrated reinforcing mesh for strength.

**NO NEED FOR POST FORM REVEALS:**

No need to double frame to achieve brick like reveals.

**M-SERIES SYSTEM -  
A WEATHER-TIGHT, ENERGY EFFICIENT,  
INSULATED WALL CLADDING SYSTEM.**

**FRAMED CONSTRUCTION.  
DIRECT TO FRAME.**





**TIMBER OR METAL STUD FRAME.**

**INTERNAL PLASTERBOARD LINING.**

**MASTERWALL BREATHER WRAP:**

A superior translucent breather type paper which provides a high performance vapor control.

**PREMIUM QUALITY  
MODIFIED LIQUID SEALANT:**

Creates a gasket seal between back of panel and the flashing tape.

**ALUMINIUM OR  
TIMBER WINDOW.**

**MASTERWALL SELF ADHERING  
FLASHING TAPE:**

A high performance flashing system uniquely formulated for MasterWall.

**POLYURETHANE FOAM SEALANT:**

All cavities around penetrations filled with polyurethane sealant.

**RENDER PROCESS:**

M-TEX acrylic render system including fiberglass mesh jointing tape to all panels and 45° to all corners of openings.

# SYSTEM SPECIFICATION

## M-SERIES EXPLODED VIEW DIAGRAM

Frame Construction	2
--------------------	---

## INTRODUCTION

Description	8
Application	8
Composition	8
Manufacture	8
Sizes & Thicknesses	9
Manufacturing Tolerances	9
Density	9
Water Vapour Resistance	9
Fire Performance	9
Colour & Packaging	9
Warranty - 7 years	9
Limitation of Liability	9

## PROPERTIES

Thermal Performance	10
Acoustic Performance	10
Bushfire Attack Level (BAL 29)	10
Impact Resistance	10
Weatherproofing	10
M.S.D.S.	10
Substrates	11
Trims and Starter Channels	11
Reinforcing Mesh	11
Flashing Tape	11
Joint Sealant	11
Window Flashing Sealant	11
Screw Fixings	12

## INSTALLATION

Breather Frame Wrap	13
Layout	13
Supporting Framework	13
Cutting	13
Health & Safety	13

## SYSTEM SPECIFICATION

### INSTALLATION - Continued

Fixing To Framing	14
Sealing - Joints	14
Sealing - Openings	14
Sealing - Other Penetrations	14
Control Joints and Articulation Relief Joints	15
Corners, Edges, Openings & Returns	15
Skyline System	16
Render System	16
Render System (BAL 29)	16
Finishing	16
Storage, Handling, Protection	16
Repair	17
Waste Management	17

### DISCLAIMER 17

### Masterwall M-Series complies with the BCA 2019 provisions and State or Territory variation(s).

Refer to [masterwall.com.au/downloads](https://masterwall.com.au/downloads) to view the complete Certificate of Conformity.



## CONSTRUCTION DETAILS

<b>Set out advice for 450 centred stud wall</b>	
50, 75, 100 & 125mm M-Series panel	18
<b>Set out advice for 600 centred stud wall</b>	
75, 100 & 125mm M-Series panel	19
50mm M-Series panel	20
<b>Set out advice for openings</b>	
50, 75, 100 & 125mm M-Series panel	21
<b>Typical corner joints</b>	
50, 75, 100 & 125mm M-Series panel	22
<b>Typical joints between panels</b>	
50 & 80mm M-Series panel	23
<b>M-Series panel / brick veneer</b>	
External corner - junction - 1	24
External corner - junction - 2	24
Construction control joint - junction - 3	25
Internal corner - junction - 4	25
<b>M-Series panel / cement fibre board</b>	
Junction	26
<b>M-Series panel / M-Series panel</b>	
Construction control joint	26
Control joint - mid floor break	27
<b>M-Series panel / brick veneer</b>	
Junction - first floor level step out	28
Junction - first floor level flush joint	29
<b>M-Series panel</b>	
Balcony - solid floor junction	30
Overhanging first floor level	31
Lower roof junction - rear flashed	32
Lower roof junction with additional faux flashing	33
Universal Junction	34
Universal Junction - external corner	34
Universal Junction - internal corner	35
Universal Junction - solid masonry	35

## CONSTRUCTION DETAILS

### **M-Series panel - continued**

Rendered Parapet Wall with Skyline System Water Proofing	36
Roof junction / parapet wall	37
Roof junction pitched roof with soffit lining	37

### **M-Series panel / timber window**

Typical head detail	38
Typical sill detail	38
Typical side jamb detail	38

### **M-Series panel / aluminium window**

Typical head detail	39
Typical sill detail	39
Typical side jamb detail	39

### **M-Series panel & brickwork junction**

Ground level	40
--------------	----

### **M-Series panel & concrete stump construction**

Protruding panel	41
------------------	----

### **M-Series panel & concrete stump construction**

42

### **M-Series panel & ground slab junction**

43

Within rebate

### **M-Series panel & ground slab junction**

Protruding	44
------------	----

### **M-Series panel / external wall**

External support with Skyline System water proofing	45
---	----

### **M-Series panel**

Panel penetration	46
-------------------	----

### **M-Series panel aluminium sliding door**

Typical head detail	47
Typical sill detail	47
Typical jamb detail	47

### **Typical fixing support for down pipe/external fittings**

50, 75, 100 & 125mm M-Series panel	48
------------------------------------	----

System Checklist	49
------------------	----

## INTRODUCTION

### Description

**M-Series** ready-to-render polystyrene panel is an external lightweight, reinforced, insulating wall panel, mechanically fixed to the outer face of the building. The panels are completed by the application of an approved acrylic render, trims, sealants, opening flashings and decorative and waterproof coatings.

Traditional sand/cement render is not suitable on the **M-Series** panels.

The base material is Medium (M) Grade expanded polystyrene (EPS) in sheet form with an applied facing of a cementitious-based material. This facing is reinforced with a fiberglass mesh. The facing is compatible with approved acrylic render and decorative finishes.

EPS (and the combination of EPS and acrylic render) has a 60-year history of use in Europe and North America. **M-Series** complies as a Performance Solution with the NCC 2019, BCA Volumes 1 & 2.

### Application

**M-Series** ready-to-render polystyrene panel is appropriate for use on timber and steel-framed residential and commercial buildings. It may also be applied to concrete and masonry.

The lightweight panels are convenient to install and add minimum weight to the structure.

The product's thermal insulation properties contribute to the energy efficiency of the building.

The ability to accept a range of approved acrylic render and decorative finishes allows a variety of aesthetic styles to be achieved, including traditional, heritage and modern.

The large panels are speedily installed, providing early enclosure and weatherproofing – assisting the achievement of early lock-up stage.

### Composition

Panel: Medium (M) Grade expanded polystyrene (EPS) with included flame retardant. Grey in appearance.

Facing: Flexible cementitious material designed for both an excellent mechanical fix and a natural chemical bond with the binders and polymers found in approved acrylic render systems. The finished surface has a light trowel type texture.

Reinforcing: A layer of alkaline-resistant fiberglass mesh, 145gm/m<sup>2</sup> minimum.

### Manufacture

The panels are manufactured locally from Australian and imported materials. The reinforced facing is mechanically applied to the previously cured EPS panels.

**!** As water ingress into timber frame can cause significant movement and thus risk cracking the external render, total frame protection from weather ingress should be implemented prior to the installation of the **M-Series**. If for any reason, moisture is apparent in the timber frame after installation, this should be allowed to dry out thoroughly prior to the application of render.

**!** It is recommended that the installation of internal linings to all external walls should be completed prior to the start of the render process of the **M-Series** System. If installing internal linings after the completion of external render, use screw fixings only, as hammering nails will crack external render.



### Sizes & Thicknesses

**Standard panel size:** 2400mm x 1200mm

**Nominal thickness:** 50mm, 75mm, 100mm, 125mm

**Area:** 2.88m<sup>2</sup>

#### Mass:

Thickness	50mm	75mm	100mm	125mm
kg/m <sup>2</sup>	2.4	2.9	3.4	3.9
Total sheet kg	6.9	8.4	9.8	11.3

If other thicknesses are required, please consult Masterwall Australia.

### Manufacturing Tolerances

**Length:** 2400mm ± 10mm

**Width:** 1200mm ± 5mm

**Thickness:** ± 1.0mm

### Density

20kg/m<sup>3</sup> (polystyrene only)

### Water Vapour Transmission

520 ug/m<sup>2</sup>s (AS2498.5)

### Panel Fire Performance AS/NZS 1530.3

- a. Ignitability = 5
- b. Spread of flame = 0
- c. Heat evolved = 1
- d. Smoke developed = 4

### Colour & Packaging

The reinforced facing has a distinctive light colour. The panel is branded **M-Series**. **M-Series** is a registered trademark of Masterwall Australia Pty Ltd.

### Warranty - 7 years

**Masterwall Australia Pty Ltd** warrants that its products are free from defects in materials and workmanship for a period of 7 years from the date of purchase. For a full description of the Warranty refer to the Masterwall Australia website (<http://www.masterwall.com.au>).

### Limitation of Liability

Except as provided for in the warranty above, **Masterwall Australia Pty Ltd** is not liable for any direct, indirect or consequential loss which any user suffers, incurs or is liable for in connection with the supply of **Masterwall Australia Pty Ltd's** products, including without limitation, direct, indirect or consequential loss arising from third party claims occasioned by defects in products.

# PROPERTIES

## Thermal Performance

### M-Series Direct to Frame

Panel Thickness	Material R-value	Timber Framing		Steel Framing	
		Total R-value (Winter)	Total R-value (Summer)	Total R-value (Winter)	Total R-value (Summer)
50mm	1.3	1.8	1.7	1.8	1.7
75mm	2.0	2.5	2.4	2.4	2.3
100mm	2.6	3.2	3.0	3.1	3.0
125mm	3.3	3.9	3.7	3.8	3.6

All thermal calculations are compliant with Australian Standard AS/NZS 4859.1:2018 (published 19/11/2018) which now include the allowance of thermal bridging of the timber/steel frame.

The complete system R Rating including **M-Series** panel, breather wrap, stud frame cavity and 10mm plasterboard. Full system 'calculation of thermal performance' available upon request.

As significant variations occur in both thickness and/or number of layers applied (as well as the types of approved acrylic render used on external walls), an R Rating is not applied to the completed render finish.

The optional thicknesses of the panel provide the opportunity to achieve higher R Ratings without the need to install additional materials.

Although the finished **M-Series** panels are water resistant, a breathable frame wrap is required over framing. If a reflective insulation is required for enhanced thermal performance or to achieve other construction characteristics, that material is to be a **breather grade** – to allow for vapour transmission.

## Acoustic Performance

The rendered **M-Series** system has been tested to AS 1191-2002 for Airbourne Sound Insulation. The STC rating is 35. (note this does not include sound control batts). **M-Series** panels can be used as part of a total wall system to achieve various Rw (Weighted Sound Transmission Index) and STC (Sound Transmission Class) ratings. Please contact Masterwall Australia for further information.

## Bushfire Attack Level (BAL 29)

The **M-Series Direct to Frame** system achieves BAL 29 when installed in accordance with this manual, including the M-TEX render system by Masterwall.

Only the M-TEX render system is certified to BAL 29, and each of the specific products must be used. For M-TEX system brief, refer to page 16 'Render System (BAL 29)' and consult Masterwall for spec and data sheets.

## Impact Resistance

When correctly installed, **M-Series** panels offer similar resistance to impact and damage as other common non-metallic sheet materials. In addition to this feature, the panels will not shatter or fracture beyond the area of impact. Minor damage will be partly corrected by the self-recovery properties of the EPS.

## Weatherproofing

The **M-Series** system provides a weatherproof facade with drainage cavity to the building having been tested to comply with the Verification Method FV1 in Volume 1 of the NCC and V2.2.1 of Volume 2. Full reports available on request.

**M.S.D.S.**

A Material Safety Data Sheet (MSDS) is available for **M-Series** panels. Please contact **Masterwall Australia**.

**Substrates****Timber framing must comply with:**

AS 1684 - National Timber Framing Code.

**Metal framing must comply with:**

AS 3623 - Domestic metal framing.

Structural bracing is to be integral to the wall frame system.

**M-Series** System does not contribute to the structural integrity of the framing.

**The control factors for installation of M-Series panels are:**

**Support Spacing:** 450mm & 600mm framing.

**Building Classes:** 1 to 10

**Wind Loadings:** N1 to N4 (classes 1 & 10). Up to 3 kPa (classes 2-9)

**Cyclonic:** C4 on 450mm steel or timber stud spacings.

**Trims and Starter Channels**

Mesh reinforced alloy corner trims are preferred and are to be applied to all external corners/openings. Galvanised or stainless steel trims are not recommended.

Starter channels are PVC and sized to the equivalent panel thickness.

**Reinforcing Tape**

Alkaline-resistant fiberglass reinforcing mesh (5mm x 5mm), minimum 150mm - 200mm wide, 160gm/m<sup>2</sup> must be installed over all panel joints.

**Flashing Tape**

Flexible adhesive backed Aluminium **M-Series** Flashing Tape typically used around windows, doors and underneath control joints as a high quality adhesive flashing system.

**Joint Sealant**

A flexible urethane foam sealant should be applied to all butt joints - see page 25.

**Window Flashing Sealant**

A premium quality modified liquid sealant applied to the face of the window flashing tape. Urethane foam sealants are not to be used in this application.

## Screw Fixings

Class (3) screws, 10 gauge fitted with a 50mm diameter **M-Series** plastic button. Class (3) screws are specified regardless of the geographic location.

### Maximum Fixing Spacing (mm) for M-Series Polystyrene Panel, M Grade, Minimum 50mm Thickness

Design ULS Pressure (kPa) (AS/NZS 1170.2)	Stud Centres	
	450mm	600mm
1.00	400	400
1.50	400	400
2.00	400	400
2.50	400	350
3.00	400	300

### Maximum Fixing Spacing (mm) for M-Series Polystyrene Panel, M Grade, Minimum 75mm Thickness

Design ULS Pressure (kPa) AS/NZS 1170.2)	Stud Centres
	450mm
1.80	400
2.70	350
4.02	200

#### NOTES:

1. The use of M-Series Direct-To-Frame System has been validated for Serviceability Limit State Pressures up to +0.82kPa and -1.23kPa for Weatherproofing Performance.

### Maximum Fixing Spacing (mm) for M-Series Polystyrene Panel, M Grade, Minimum 50mm Thickness

AS 4055 Wind Classification	Stud Centres 450mm		Stud Centres 600mm	
	Further than 1.2m of the corners	Within 1.2m of the corners	Further than 1.2m of the corners	Within 1.2m of the corners
N1	400	400	400	400
N2	400	400	400	400
N3	400	400	400	400
N4	400	400	400	300

### Maximum Fixing Spacing (mm) for M-Series Polystyrene Panel, M Grade, Minimum 75mm Thickness

AS 4055 Wind Classification	Stud Centres 450mm		Stud Centres 600mm	
	Further than 1.2m of the corners	Within 1.2m of the corners	Further than 1.2m of the corners	Within 1.2m of the corners
C1	400	367	-	-
C2	350	200	-	-

## INSTALLATION

### Breather Frame Wrap

**Masterwall Australia** recommends use of **M-Series** Breather Frame Wrap or similar.

Note: Under no circumstances should a non-breathable paper be used behind **M-Series** panels.

### Layout

**M-Series** panels may be laid either vertically or horizontally (for either frame or masonry substrates) according to the best fit for the 2400mm x 1200mm sheet - horizontal, staggered joint layout is always the preferred option.

If the wall height is less than or equal to 2400mm, then practicality may dictate that the **M-Series** panel be laid vertically - but horizontal layout is the preferred option.

If the wall height is greater than 2400mm, then the panels should always be laid horizontally, in a brickwork or stretcher bond pattern, with each 1200mm vertical joint staggered up through the height of the wall.

**A horizontal layout is the preferred option.**

### Supporting Framework

**Edges of the M-Series panels may require support on studs, noggings or other intermediate blocking.**

**M-Series** panels may be cantilevered or projected beyond supports by the same distance as a given panel's thickness.

Fixed-back blocking techniques are mandatory. Full-stud width (min 90mm) support is required. Back blocking timber must be MGP 10 or greater. Merchant grade is not permitted. Adhesive fixed back blocking is not permitted.

Supports to intermediate joints are required, as shown in this table.

Panel Thickness	50mm		75mm		100mm		125mm	
	V	H	V	H	V	H	V	H
Studs 450 crs	✓	✗	✓	✗	✓	✗	✓	✗
Studs 600 crs	✓	✓	✓	✗	✓	✗	✓	✗

(V = Vertical) (H = Horizontal)

Supports/blocking are required to all edges around openings.

### Cutting

**(a) Masonry Blade:** For 50mm, 75mm, 100mm & 125mm **M-Series** panels, a diamond-tipped masonry blade is the most accurate, time-efficient and clean way to cut/trim panels (see MSDS).

**(b) Hand Saw:** A fine-tooth saw is also an efficient way of cutting the **M-Series** panel.

**M-Series** panels should be accurately cut to size to produce close butt joints between panels.

### Health & Safety

Use of personal protective equipment (face masks and safety goggles) is recommended. The fine dust created by mechanical cutting is hazardous, and protection is recommended, including face masks and safety goggles.

Mechanical cutting should be performed in well-ventilated spaces. Power tools can be fitted with effective dust-extraction systems. Refer to **M-Series** Material Safety Data Sheet (MSDS).

## Fixing To Framing

- (a) Centres:** On a stud spacing of either 450mm or 600mm, fixings are to be at a maximum 400mm centres vertically to all perimeter and intermediate supports. Fixings around perimeter of panels should be 25mm in from the edge of the panel. Average 10 fixings per m<sup>2</sup> (see Wind Load Fixing Chart page 12).
- (b) Fixings:** Fixing screws and buttons should be the type and suitability as set out in this guide.
- (c) Appearance:** When fastened correctly, the screw head and button should be slightly countersunk in a concave recess on the outer surface of the panel, and located so as to not crush the edge of the panel. The button should always retain its circular shape i.e. if the button begins to flare or fold it has been screwed too far towards the frame.

## Sealing - Joints

Prior to closing up of all joints between panels (and between panels and other building elements), a flexible urethane foam is required to the centre the gap between panels.

This forms a mechanical seal for weatherproofing, and converts the many individual panels into a single monolithic, insulated skin.

Foam urethane sealant is therefore required to:

- (a)** All butt joints
- (b)** All external corners and butt jointed internal corners

## Sealing – Openings

Prior to the application of the panel, **all** openings must be flashed from the reveal to the frame. **Masterwall Australia Pty Ltd** recommends and supplies adhesive aluminium **M-Series** Flashing Tape for just this purpose, and is suitable for both aluminium and timber windows. This proven flashing method reduces the risk of water penetration. In turn, the panels are then to be sealed with a premium quality modified liquid sealant to the face of the flashing tape to form a gasket seal around the opening.

Note: **M-Series** panels should not be externally sealed to window/door reveals at this point, post installation and prior to render application. Sealants should never be rendered over, as render systems, with limited movement capabilities, will restrict a sealant's ability to move according to manufacturer's specification. Sealants for openings should be applied after the render system has been applied - never before!

## Sealing – Other Penetrations (including wiring, plumbing, joists, ducting)

Where possible all penetrations through the **M-Series System** should be treated as per window detail, incorporating flashing tape and liquid urethane sealant. This is of high importance for floor and pergola joist penetrations, electrical meter boxes, ducting and the like.

It is then recommended that a 10mm minimum clearance gap be left between the **M-Series** panel and the penetration and caulked using **M-Series** flexible expanding foam urethane sealant prior to render application.

Smaller penetrations such as plumbing or electrical conduit should have a 10mm minimum clearance gap between the **M-Series** panel and the pipe and caulked using **M-Series** approved flexible expanding foam urethane sealant prior to render application.

Note: Extra mesh tape is required around the penetration for added reinforcing during the render process.

**Masterwall Australia Pty Ltd** recommends the use of liquid sealants to all timber windows after the rendering process has been completed. Please note that render systems are not sealants i.e. an opening cannot be sealed by the application of an acrylic render system. Render systems are water-shedding technologies, not weather-proofing technologies.

### **Control Joints and Articulation Relief Joints**

Control joints for expansion should coincide with control joints within the building structure and substrate, and should be placed at all perceived stress points or weak areas of excessive movement within the building structure. Control joints should be placed at a maximum of walls that are over 6 meters long and at all mid-floor breaks. It is recommended that panel area below windows that is less than 300mm in height should be relieved with 'Articulation Relief Joints' of the render coating, at the corners of the opening (see Finishing: page 16). Contact Masterwall Australia for further information.

Articulation relief joints of the render coating are to be formed by cutting or forming a 'V' groove into the completed base coats, only to 70% depth of the render, not into the **M-Series** panel. The applied top coats shall replicate the 'V' groove to leave a visible line.

Where control joints are part of the building construction, the joint is to be expressed in the **M-Series** panels as an open joint, free of construction urethane, and finished as for all other open edges (including external corners applied to each edge).

Panel to panel control joints should be located on double studs, which are then to be sealed with flashing tape, which is then sealed to the rear of each panel with the use of a premium quality modified liquid sealant.

All control joints should feature either Ableflex (or similar) or backer rod as the primary seal, which should be set back in the control joint a minimum of 8mm where it must be caulked by others after the render process has been completed. – See Construction Details Manual. All Control Joints should be free of render products.

### **Corners, Edges, Openings & Returns**

All panels to external corners must be butt joined (square) to give maximum strength to the corner.

Butt joints are required to all internal corners. Foam urethane sealant is required in this butt joint.

To form a total weatherproof face, all joints and abutments require sealing with foam urethane sealant.

Once completed, ensure all exposed system edges are protected from direct weather, either by render system or Starter Channel.

**M-Series** Alloy External Corners or Starter Channels should be applied to all of the following areas:

- (a) All external corners
- (b) All openings
- (c) All bottom edges of panel

These trims are to be in long lengths and set accurately to be plumb, level and straight.

## Skyline System

The **Skyline System** is an architectural concealed waterproofing detail for use on parapet designs, featuring clean, uninterrupted lines. The **Skyline System** is concealed by the applied render finish and eliminates the need for unsightly pressed metal capping. It is also used as a waterproofing detail for fixing blocks within the **Masterwall** and **K-Series Systems**.

The **Skyline System** membrane is a pressure sensitive self-adhesive butyl tape, 0.75mm in thickness, containing a non-woven polyester fibre face, ready for the application of high polymer render. Able to withstand building movement, it has 35% elongation breaking limit and is serviceable from -10° to 100° Celsius.

Important Note: As the **Skyline System** is a total waterproofing detail, no fixings should ever penetrate the horizontal surface of the completed parapet. All fixings of balustrades and the like should only be mounted on the vertical wall surface only.

## Render System

When all **M-Series** panels have been installed (complete with sealants and edge trims) a 5mm minimum thickness of the M-TEX render system by Masterwall is required.

Traditional sand/cement renders are not suitable for application of M-Series panels.

All panel joints of the M-Series system require reinforcing with M-TEX 150mm alkali resistant fibreglass. Added reinforcing strips of the mesh (200mm) should be applied diagonally across the corners of all openings such as windows, doors and in wall electrical boxes.

Embed the fibreglass mesh into 3mm coat of M-TEX Pro Render, once set apply a further levelling coat of M-TEX Pro Render to achieve the required thickness. The final finish is achieved with the application of an M-TEX Marble coloured texture of choice. For full M-TEX specification and data sheets, please consult Masterwall.

Articulation relief joints of the render coating are to be formed by cutting or forming a 'V' groove into the completed base coats, only to 70% depth of the render, not into the **M-Series** panel. The applied top coats shall replicate the 'V' groove to leave a visible line.

## Render System (BAL 29)

To achieve BAL 29, a minimum 6.5mm acrylic render system is applied to entire M-Series system. Fibreglass mesh tape is to be embedded into the first 3mm layer of acrylic render, followed by a 3mm leveling coat of acrylic render. This is completed with a minimum 1mm coloured acrylic texture system. For render system specifications consult **Masterwall Australia**.

## Storage, Handling, Protection

**M-Series** panels delivered to site should be stored flat and evenly supported. They should be covered or otherwise protected from damage or soiling.

If stored outside panel stacks are to be covered, a material/canvas cover should be utilized. Under no circumstances should a black plastic cover be used.

During installation, the **M-Series** panels should be handled with care to prevent edge damage or fracture.

Particular care is required during windy conditions, as unsecured panels can be severely damaged.

Continuous exposure may result in deterioration and minor fretting of exposed edges of the panel. This is to be removed prior to proceeding with finishing or sealing. As with all sheet materials, protection from impact damage is required.

The application of the approved acrylic render should, wherever possible, follow the installation of internal services, fittings and linings – when the risk of damage is minimised.

Timely application of the render will complete the wall system - and protect the panels from damage.



### **Repair**

Panels that are fractured or severely damaged (before or after fixing) should be rejected or cut down to size for use.

Minor penetrations, edge fractures or crushed areas may be site-patched with the reinforcing mesh and an approved acrylic patching render.

### **Waste Management**

Being lightweight, the panel material is readily dispersed by the wind. To prevent a nuisance, all off-cuts and residue from cutting should be stored in tied plastic bags for removal to a place of legal disposal. Attention to detail - in particular to spacing of backblocking - will contribute to a reduction in the amount of waste and off-cut materials.

### **Disclaimer**

Whilst every effort has been made to ensure the information in this manual is correct at the time of printing, **Masterwall Australia Pty Ltd** reserves the right to change the specifications of all products referred to in this manual at any time. All changes made to this manual are uploaded on to our website [www.masterwall.com.au](http://www.masterwall.com.au).

# 50, 75, 100 & 125mm M-SERIES

## SET OUT ADVICE FOR 450 CENTRED STUD WALL:

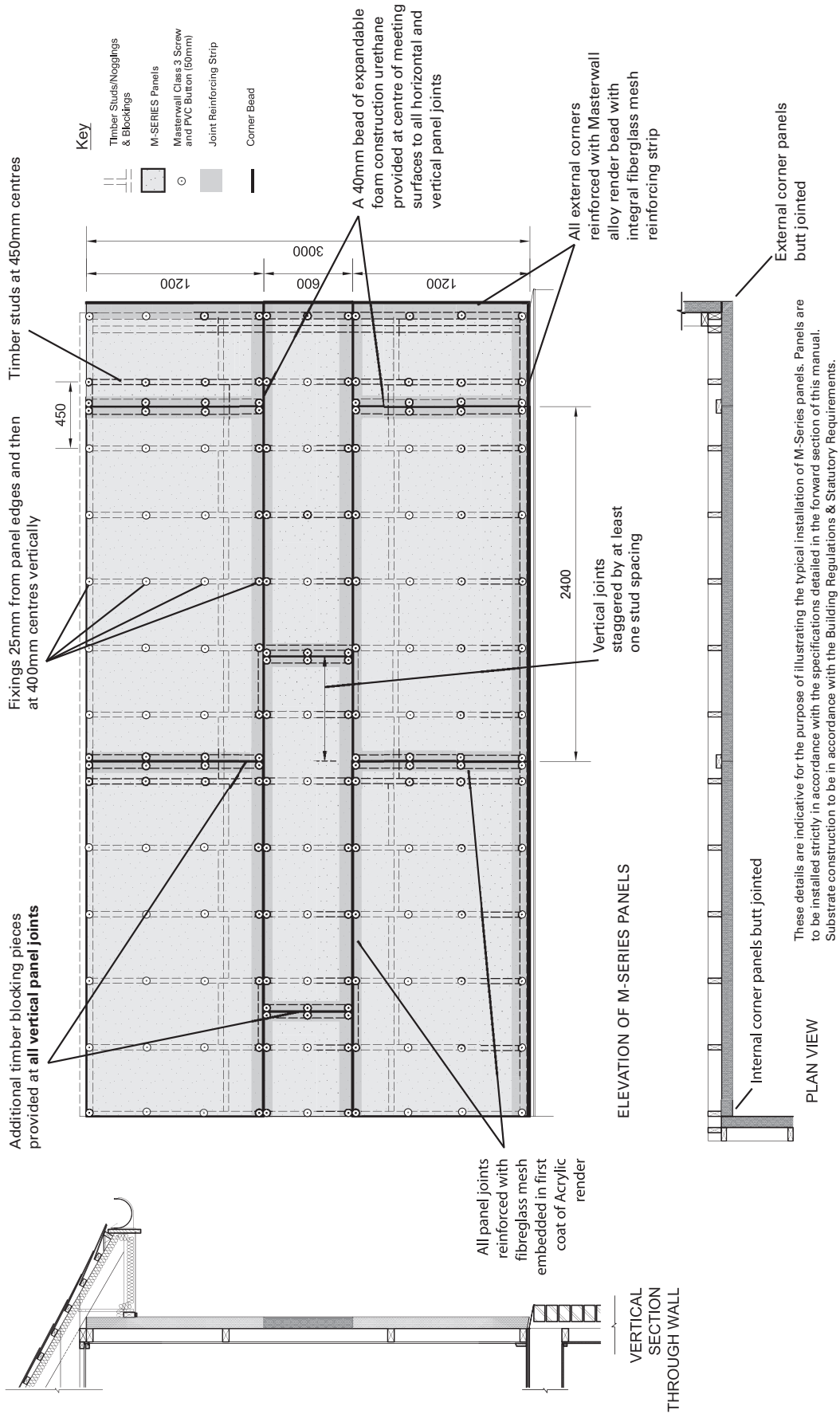

# 75, 100 & 125mm M-SERIES

## SET OUT ADVICE FOR 600 CENTRED STUD WALL:

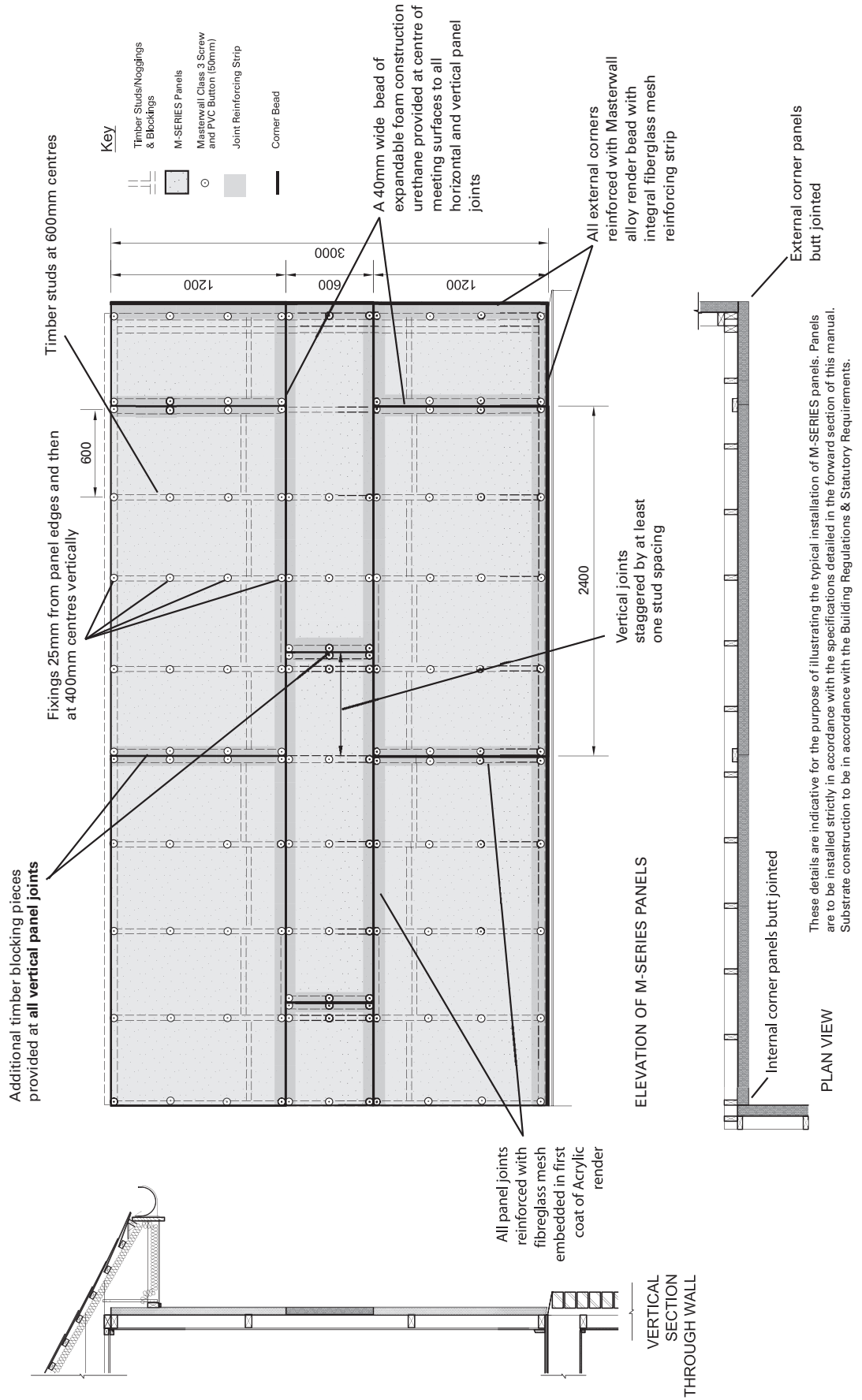

# 50mm M-SERIES

## SET OUT ADVICE FOR 600 CENTRED STUD WALL:

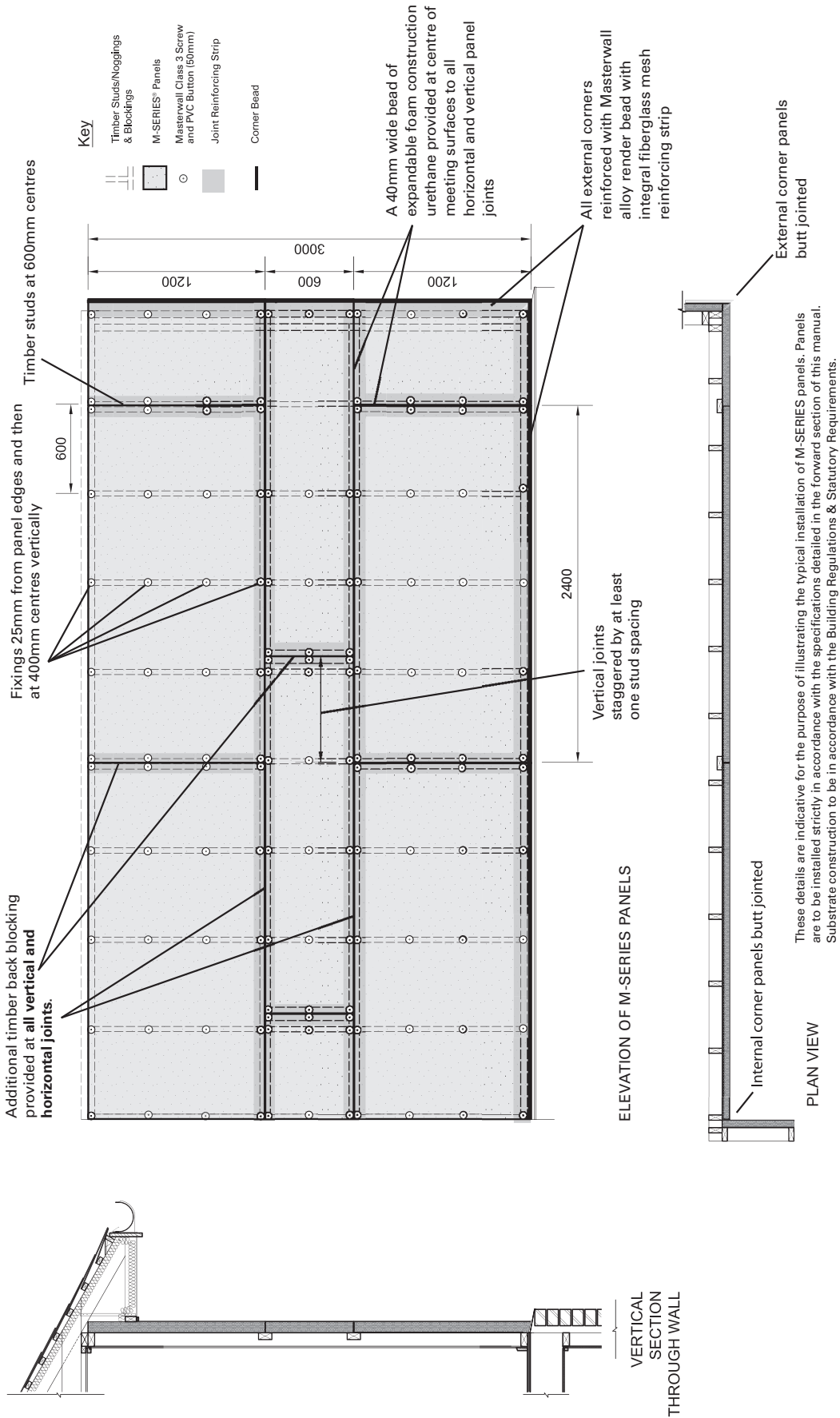

# 50, 75, 100 & 125mm M-SERIES

## SET OUT ADVICE FOR OPENINGS:

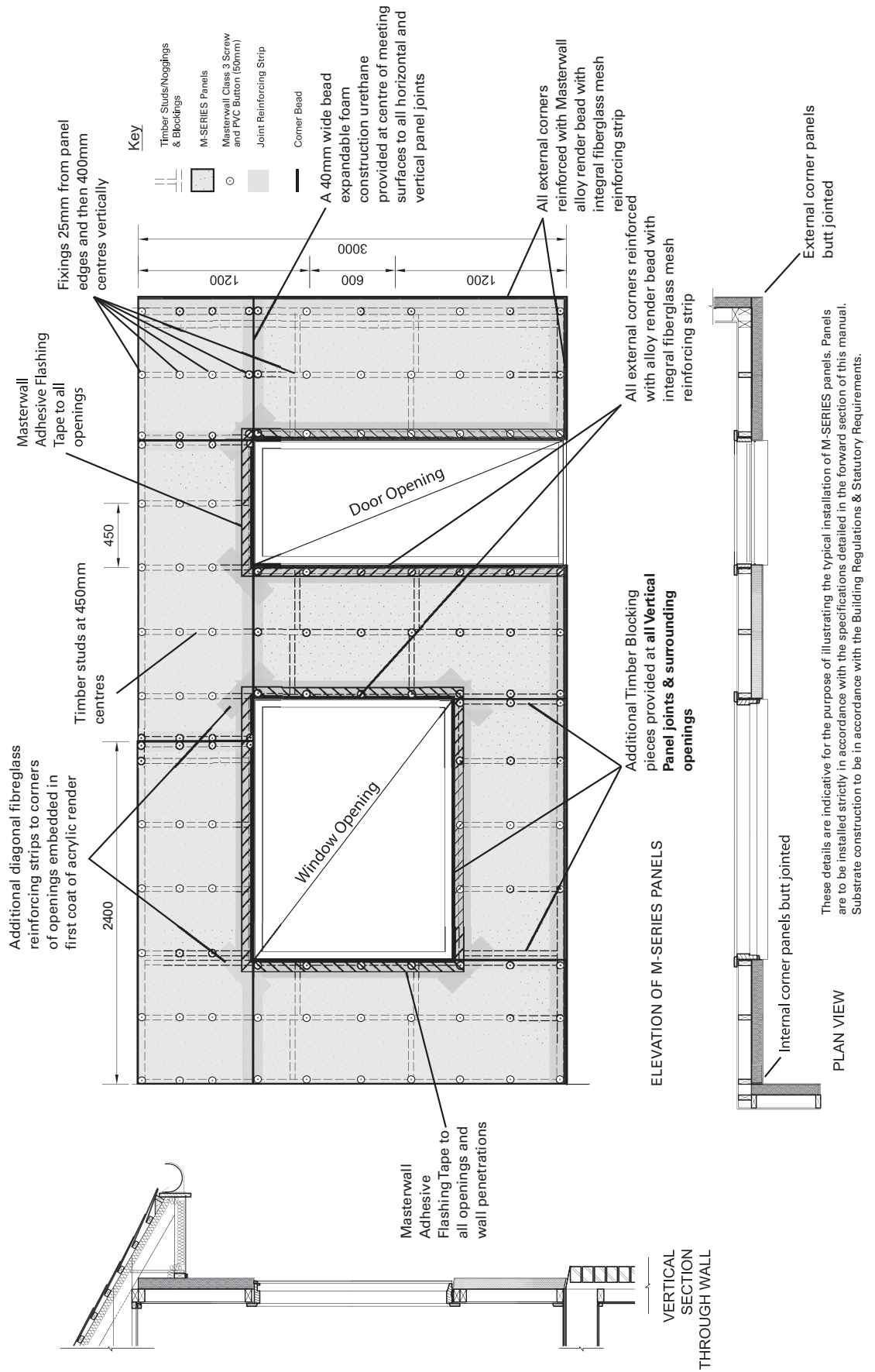

# 50, 75, 100 & 125mm M-SERIES

## TYPICAL CORNER JOINTS:

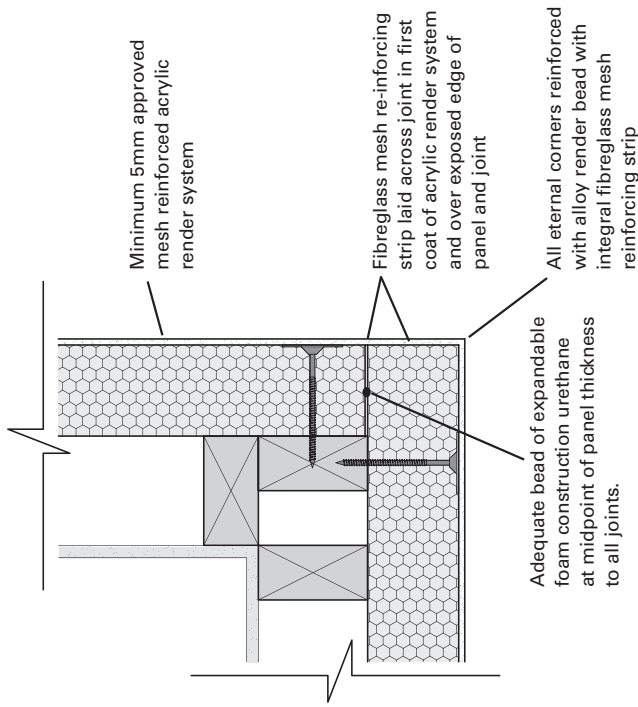

**M-SERIES Panels Butt Jointed**

## EXTERNAL CORNER - PLAN VIEW

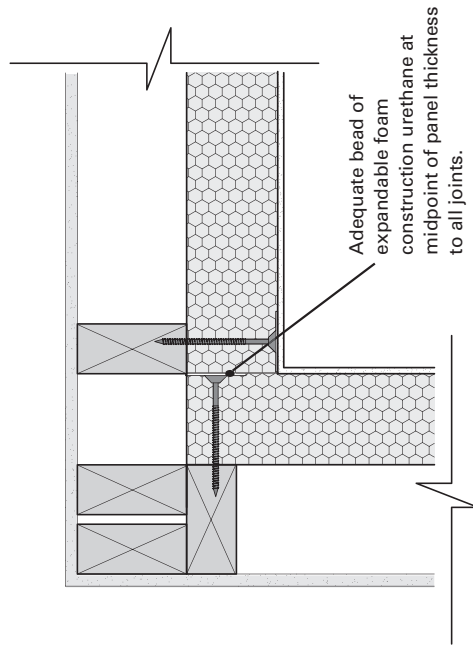

**M-SERIES Panels Butt Jointed**

## INTERNAL CORNER - PLAN VIEW

These details are indicative for the purpose of illustrating the typical installation of M-SERIES panels. Panels are to be installed strictly in accordance with the specifications detailed in the forward section of this manual. Substrate construction to be in accordance with the Building Regulations & Statutory Requirements.

# 50, 75, 100 & 125mm M-SERIES

## TYPICAL JOINTS BETWEEN PANELS:

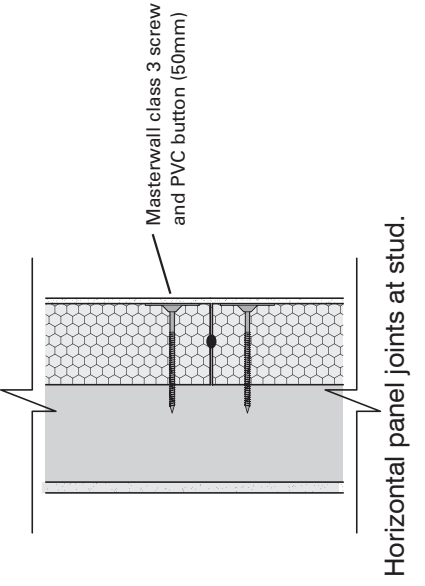

**NOTES FOR ALL FIGURES**

Screw fixing must be at least 25mm greater in length than thickness of M-SERIES panel

Adequate bead of expandable foam construction urethane at midpoint of panel thickness to all joints

Fibreglass mesh re-inforcing strip laid across joint suspended in first coat of acrylic render

Vertical joint at stud. Double stud required.

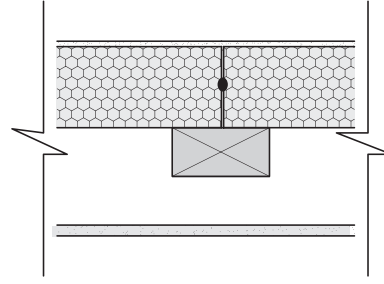

Horizontal joints of 50mm panel on 600mm centre studs. Back blocking fixed to frame required between studs.

## HORIZONTAL JOINTS - SECTION VIEW

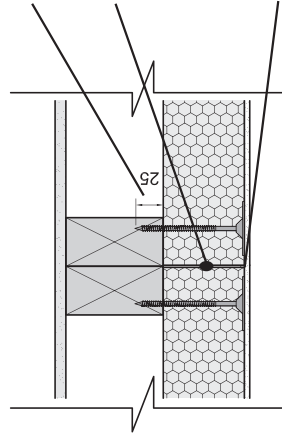

Vertical panel joints between studs. Back blocking required fixed to frame.

## VERTICAL JOINTS - PLAN VIEW

These details are indicative for the purpose of illustrating the typical installation of M-SERIES panels. Panels are to be installed strictly in accordance with the specifications detailed in the forward section of this manual. Substrate construction to be in accordance with the Building Regulations & Statutory Requirements.

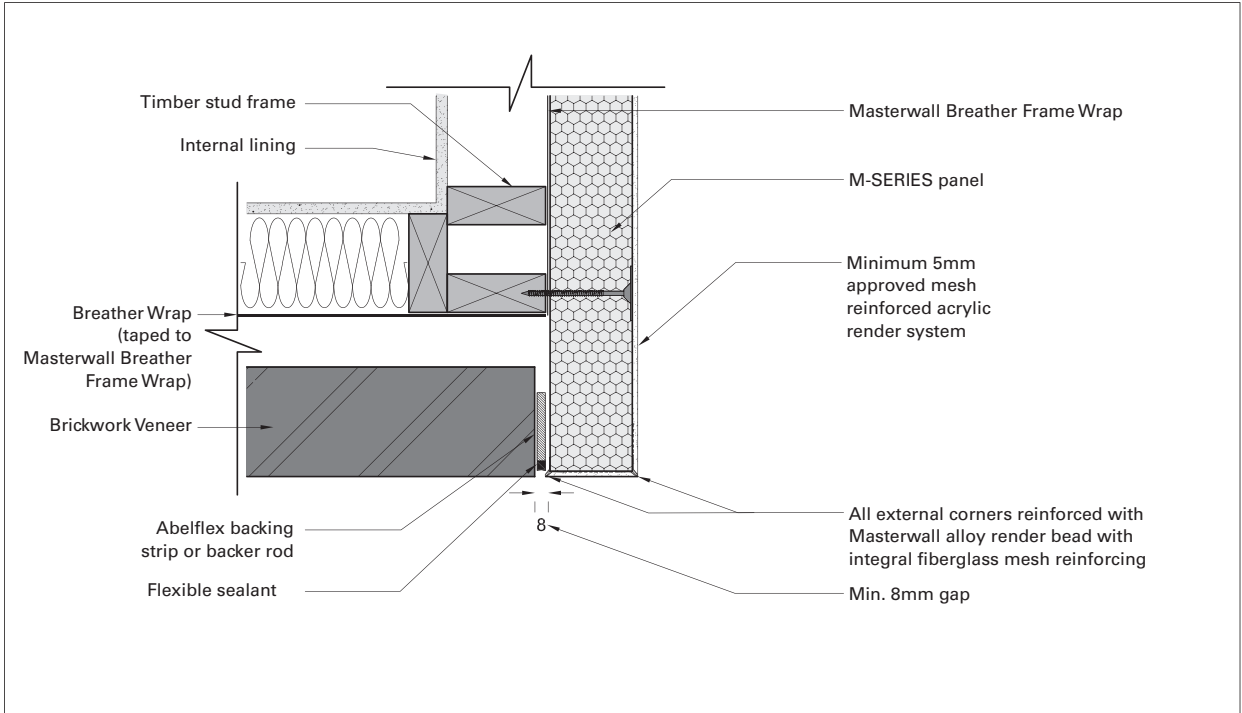

## M-SERIES PANEL / BRICK VENEER EXTERNAL CORNER: JUNCTION - 1

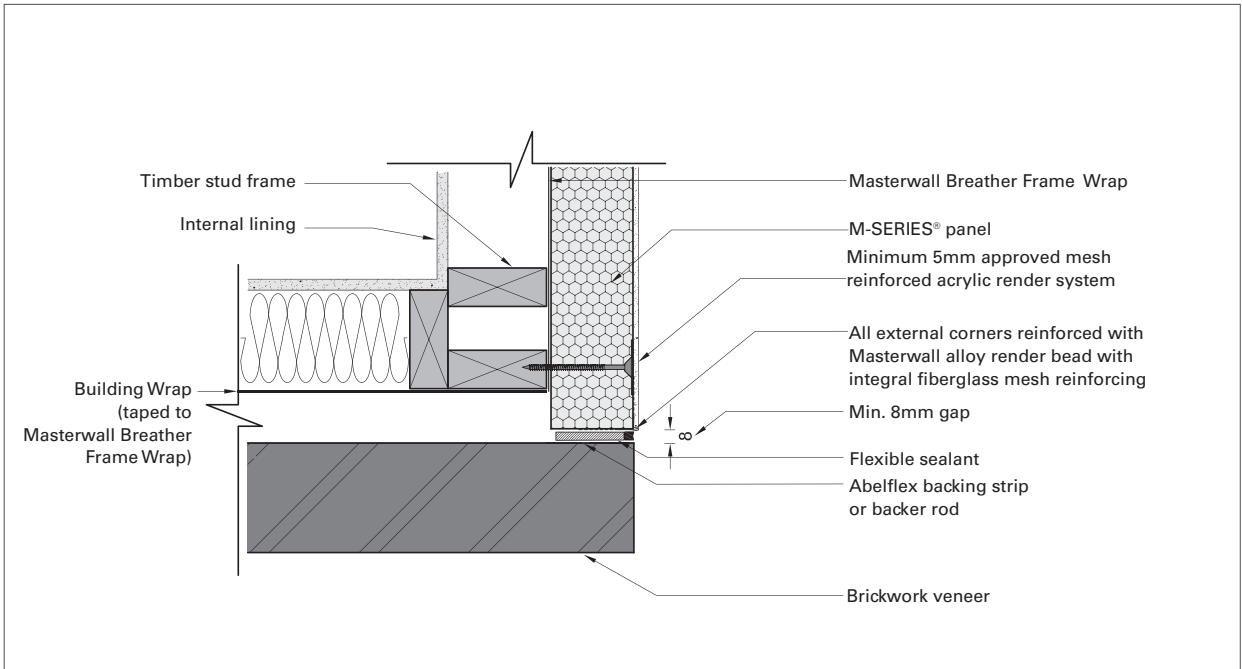

## M-SERIES PANEL / BRICK VENEER EXTERNAL CORNER: JUNCTION - 2

These details are indicative for the purpose of illustrating the typical installation of M-SERIES panels. Panels are to be installed strictly in accordance with the specifications detailed in the forward section of this manual. Substrate construction to be in accordance with the Building Regulations & Statutory Requirements.



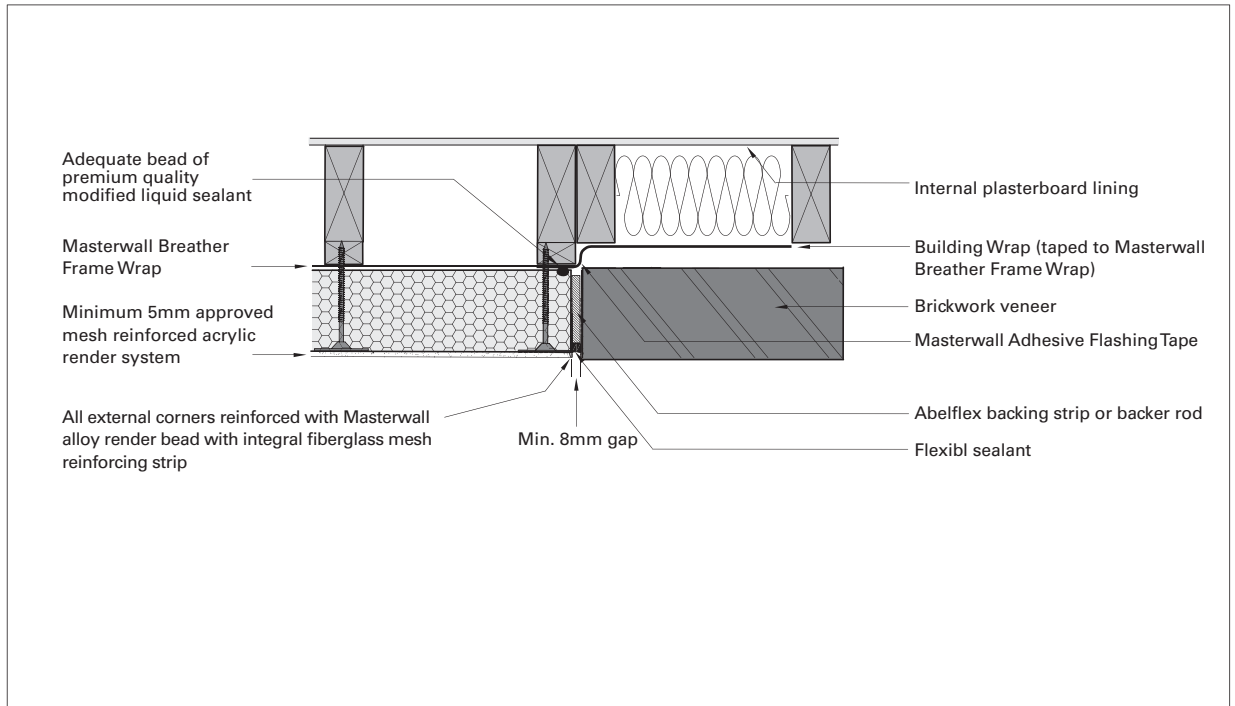

### M-SERIES PANEL / BRICK VENEER CONSTRUCTION CONTROL JOINT: JUNCTION - 3

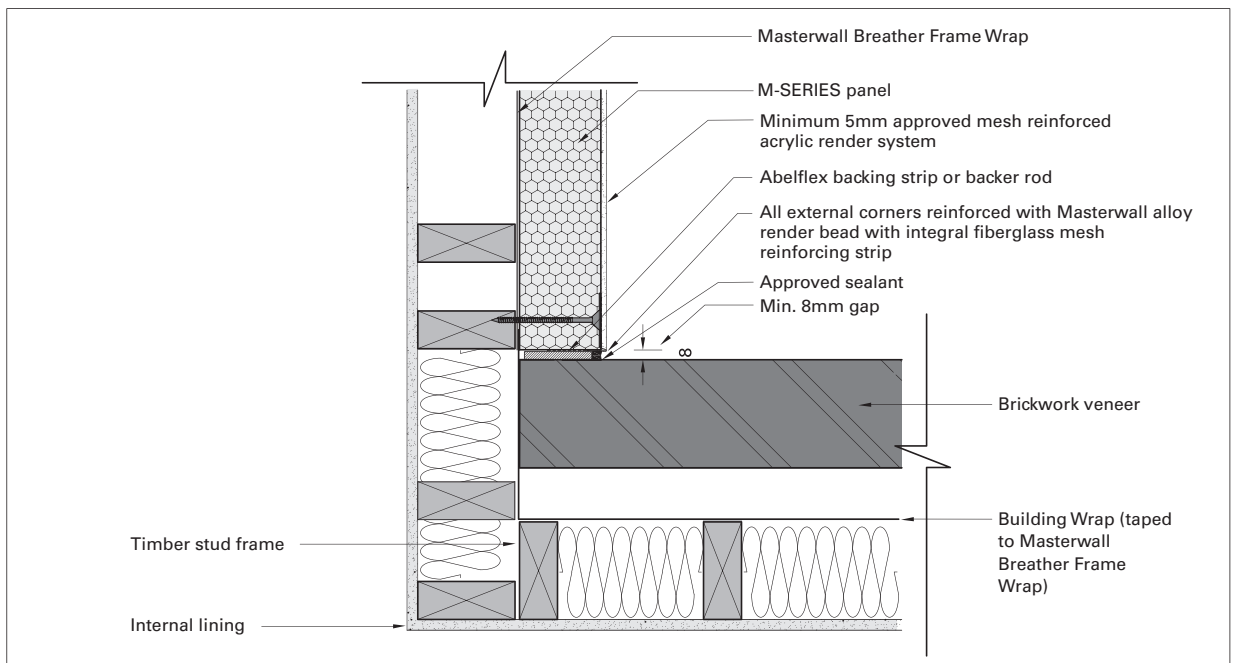

### M-SERIES PANEL / BRICK VENEER INTERNAL CORNER: JUNCTION - 4

These details are indicative for the purpose of illustrating the typical installation of M-SERIES panels. Panels are to be installed strictly in accordance with the specifications detailed in the forward section of this manual. Substrate construction to be in accordance with the Building Regulations & Statutory Requirements.

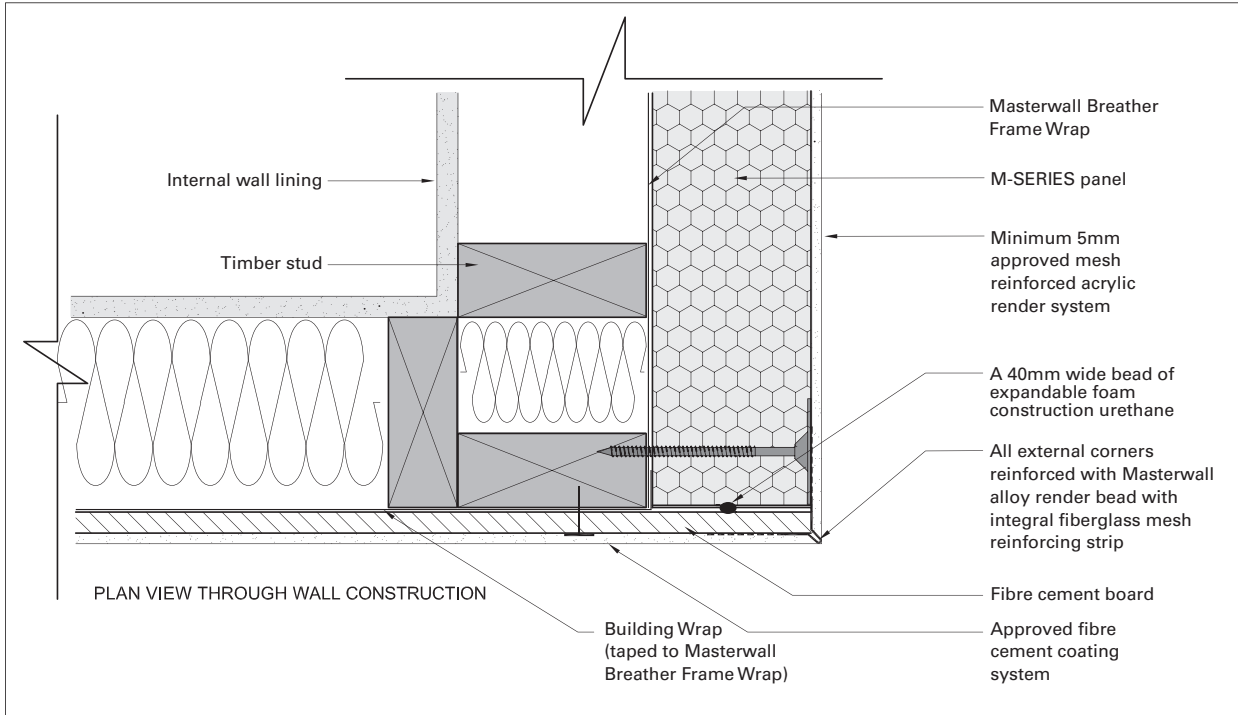

## M-SERIES PANEL / FIBRE CEMENT BOARD: JUNCTION

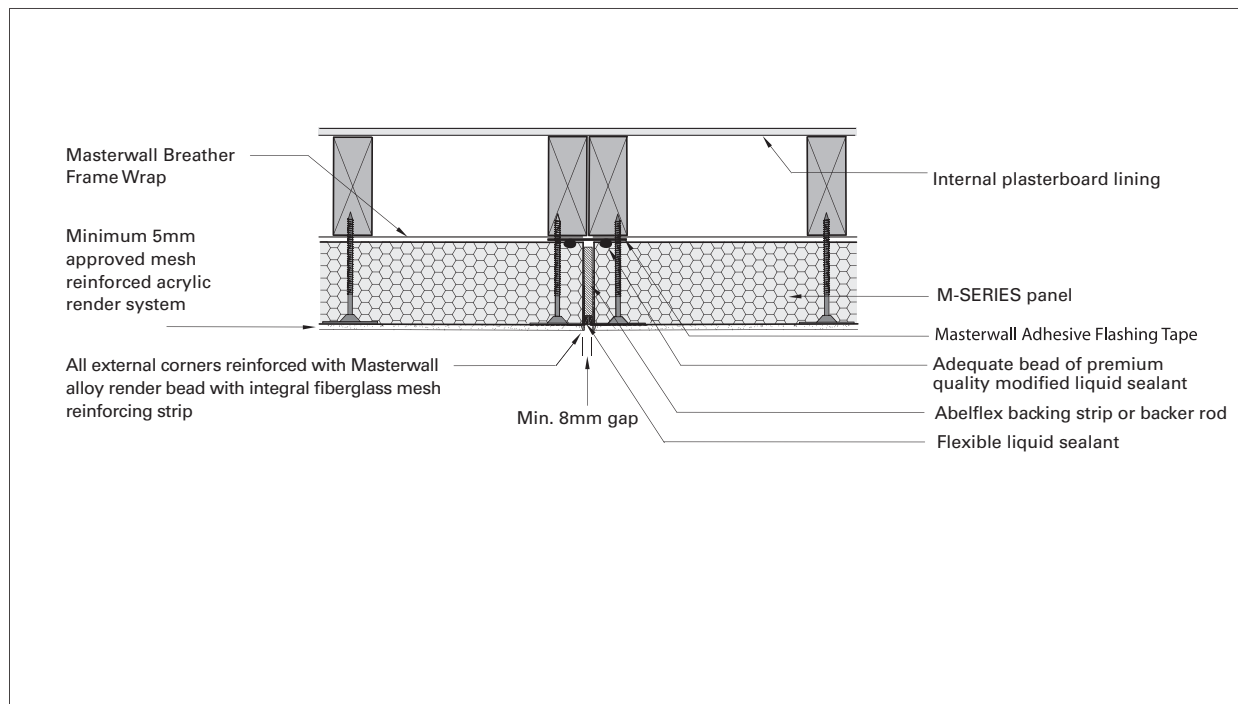

## M-SERIES PANEL / M-SERIES PANEL: CONSTRUCTION CONTROL JOINT

These details are indicative for the purpose of illustrating the typical installation of M-SERIES panels. Panels are to be installed strictly in accordance with the specifications detailed in the forward section of this manual. Substrate construction to be in accordance with the Building Regulations & Statutory Requirements.

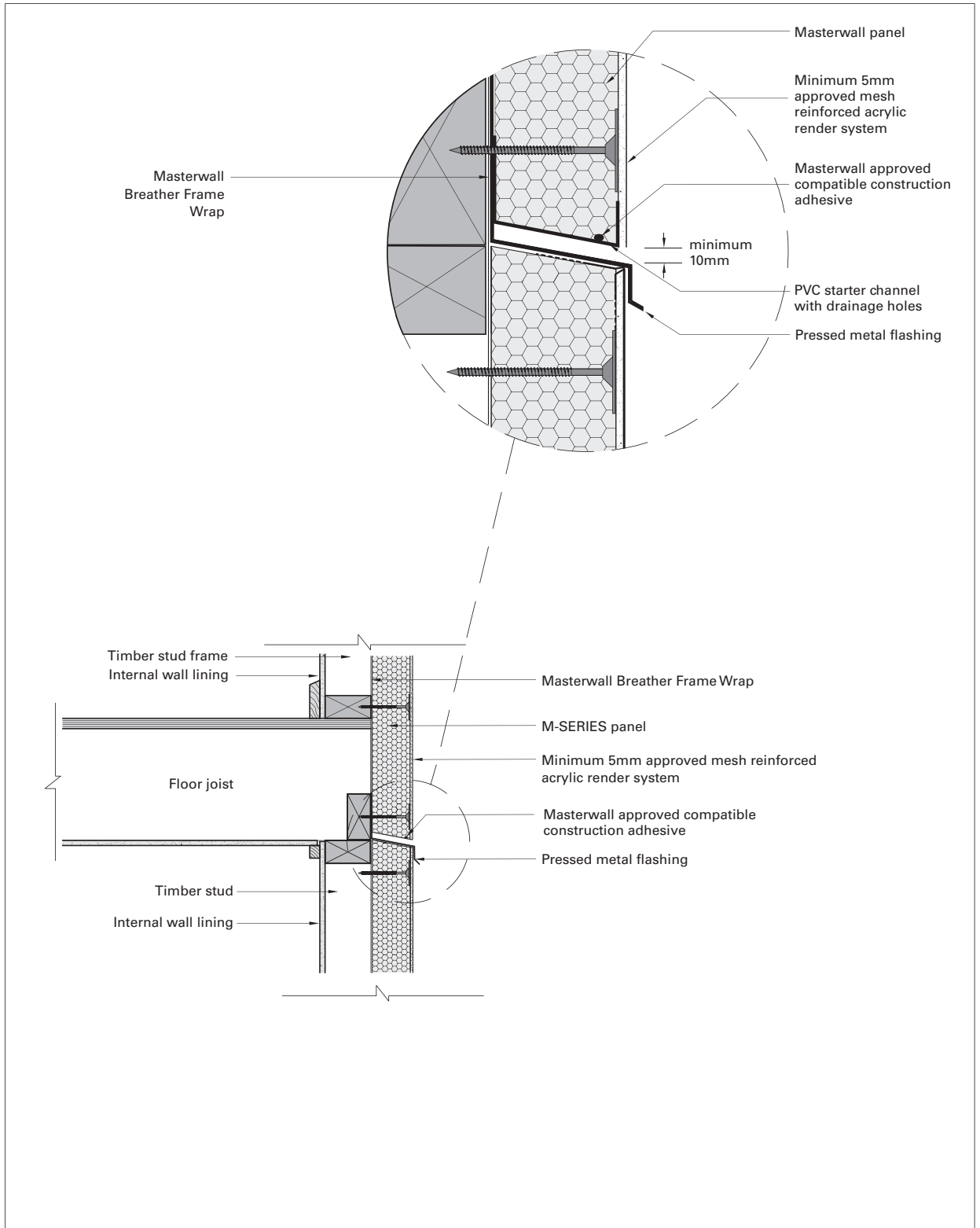

## M-SERIES PANEL / M-SERIES PANEL: CONSTRUCTION CONTROL JOINT - MID FLOOR BREAK

These details are indicative for the purpose of illustrating the typical installation of M-SERIES panels. Panels are to be installed strictly in accordance with the specifications detailed in the forward section of this manual. Substrate construction to be in accordance with the Building Regulations & Statutory Requirements.

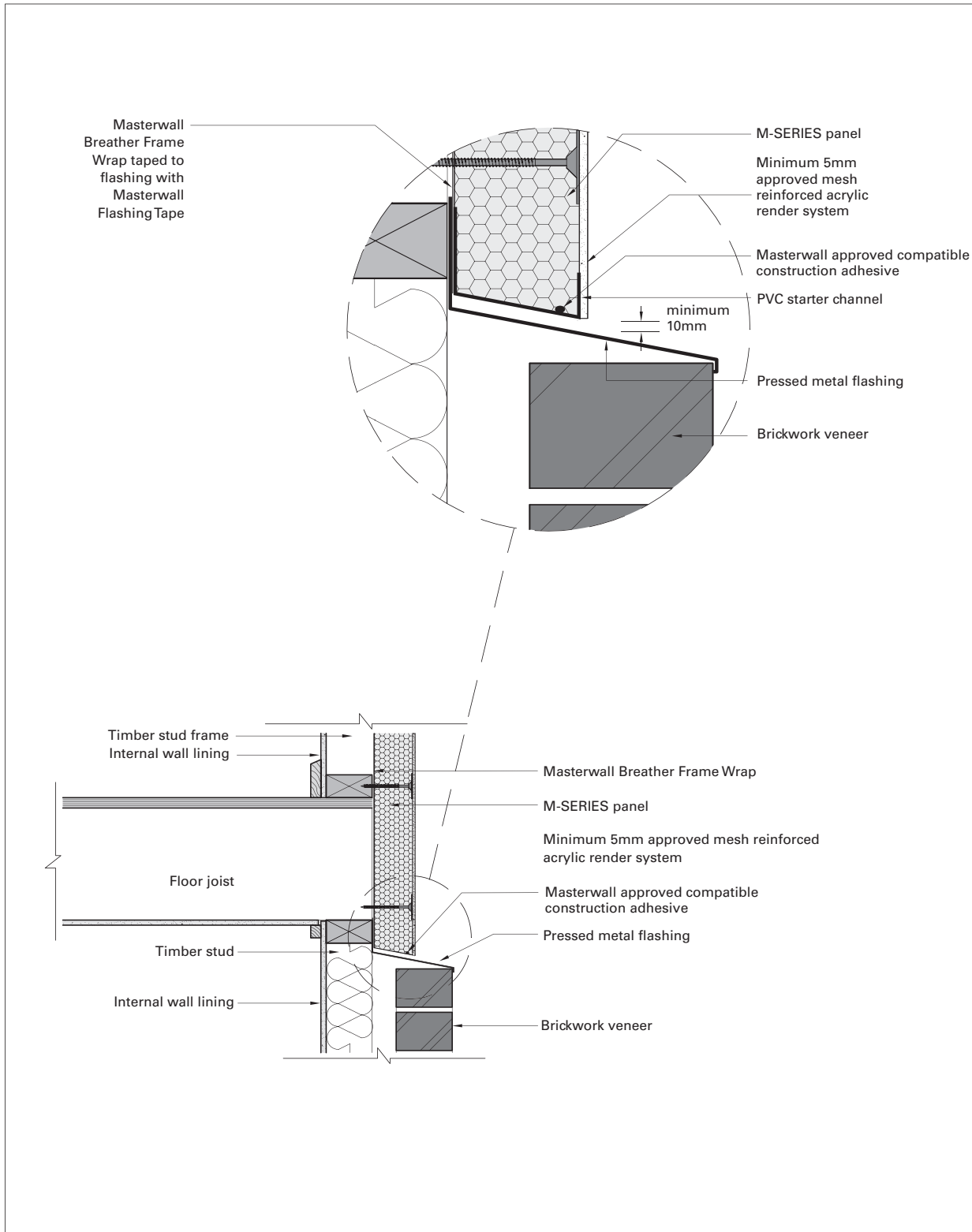

## M-SERIES PANEL / BRICK VENEER: JUNCTION - FIRST FLOOR LEVEL STEP OUT

These details are indicative for the purpose of illustrating the typical installation of M-SERIES panels. Panels are to be installed strictly in accordance with the specifications detailed in the forward section of this manual. Substrate construction to be in accordance with the Building Regulations & Statutory Requirements.

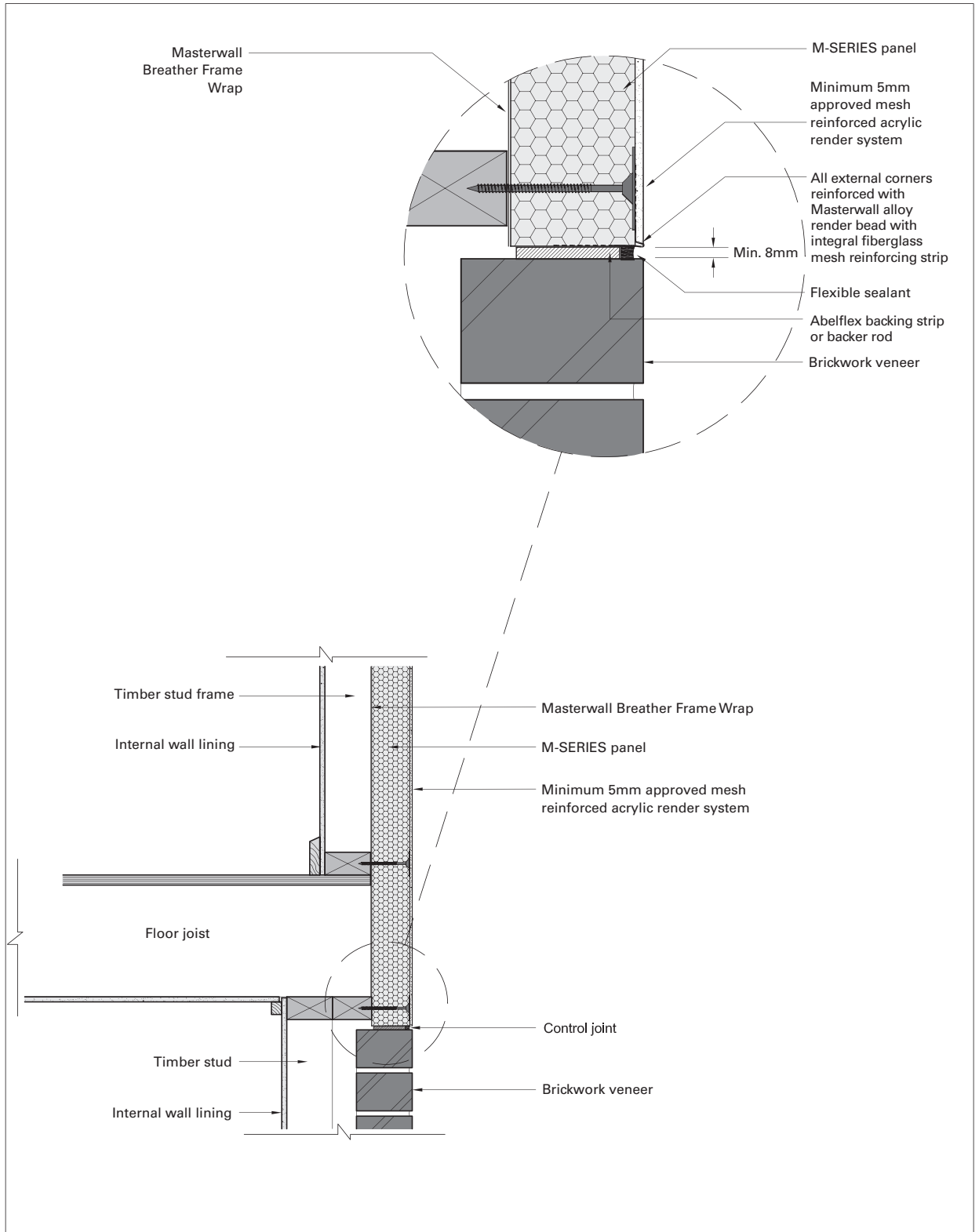

## M-SERIES PANEL / BRICK VENEER JUNCTION: FIRST FLOOR LEVEL FLUSH JOINT

These details are indicative for the purpose of illustrating the typical installation of M-SERIES panels. Panels are to be installed strictly in accordance with the specifications detailed in the forward section of this manual. Substrate construction to be in accordance with the Building Regulations & Statutory Requirements.

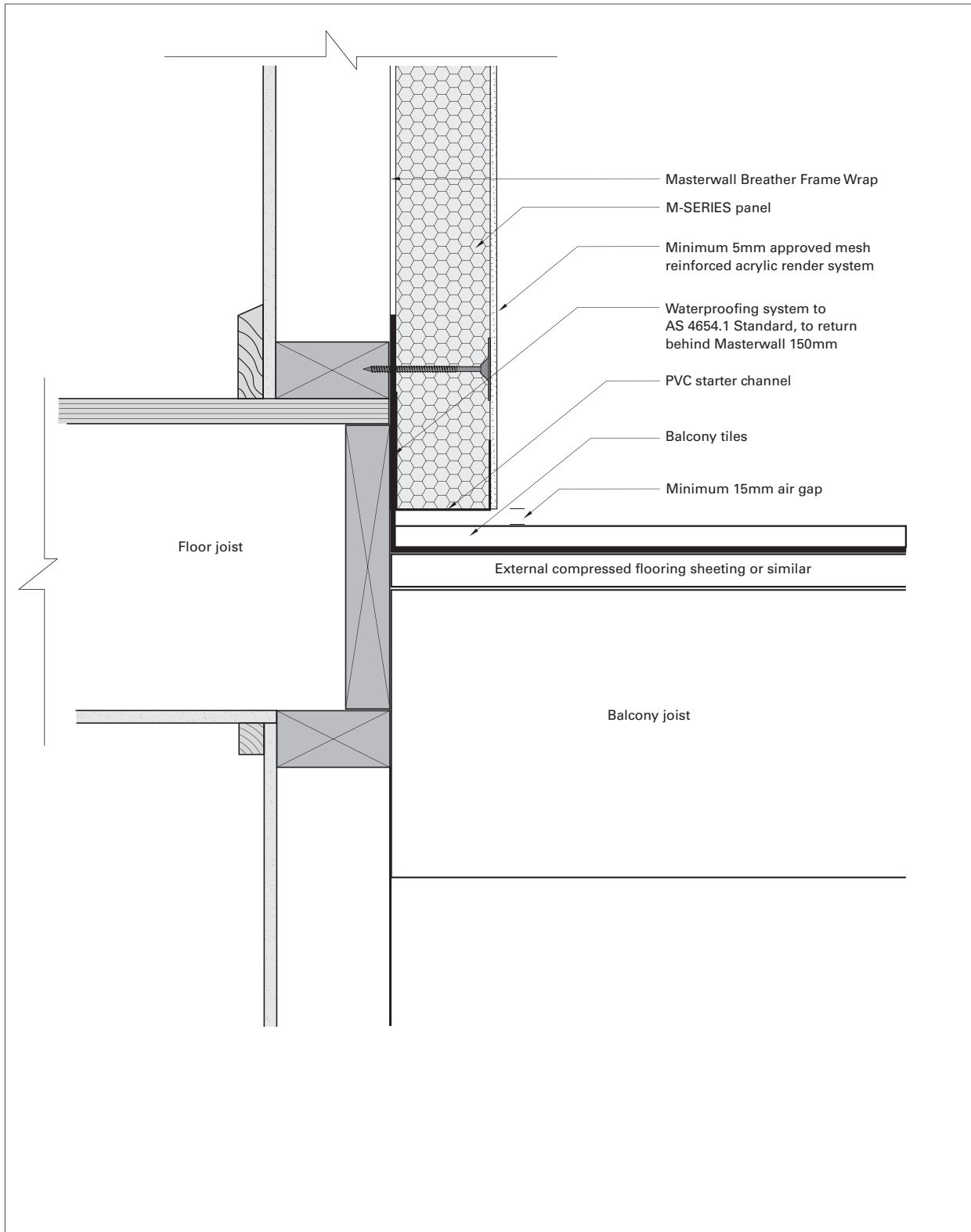

**M-SERIES PANEL:  
BALCONY  
SOLID FLOOR JUNCTION**

These details are indicative for the purpose of illustrating the typical installation of M-SERIES panels. Panels are to be installed strictly in accordance with the specifications detailed in the forward section of this manual. Substrate construction to be in accordance with the Building Regulations & Statutory Requirements.

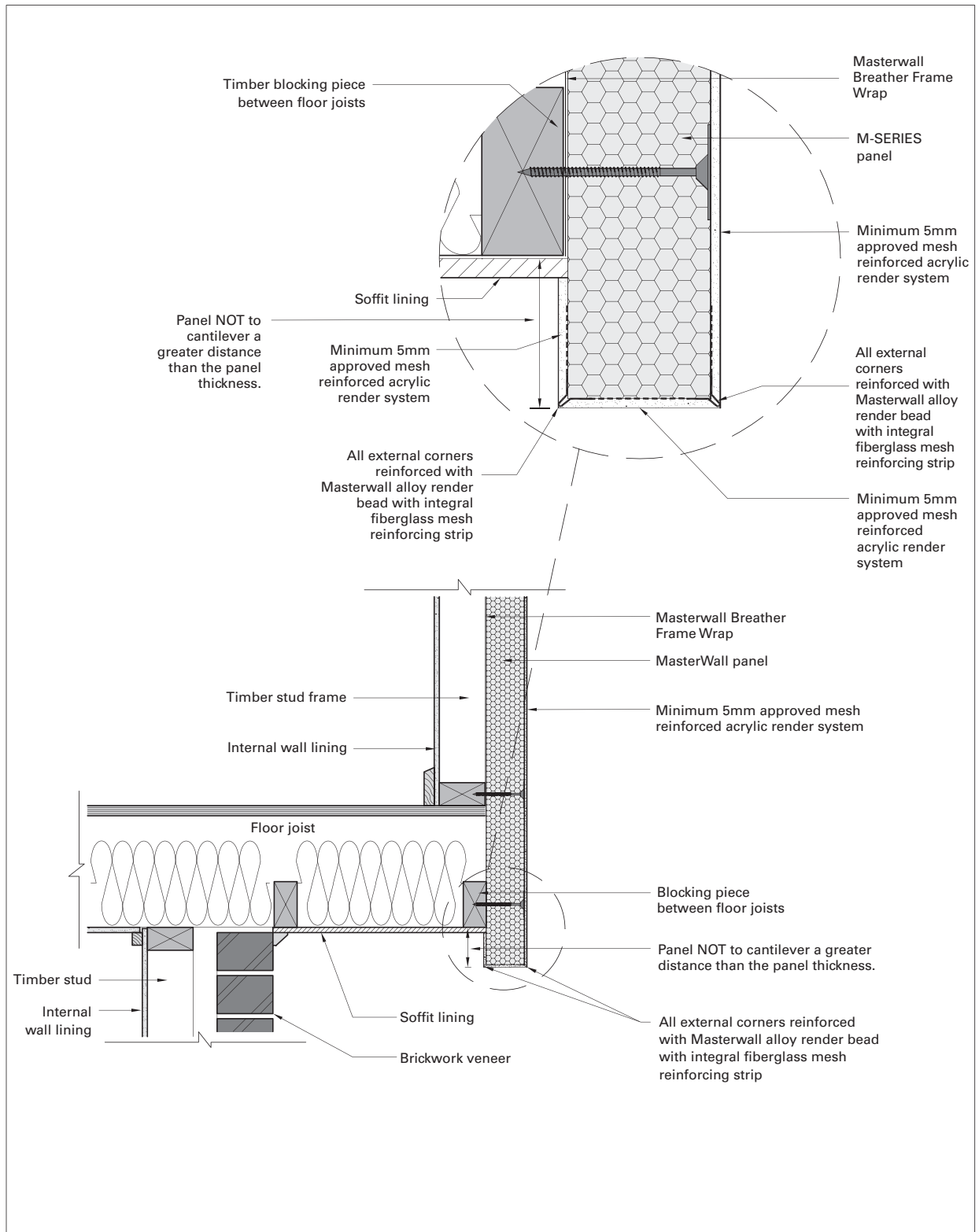

## M-SERIES PANEL: OVERHANGING FIRST FLOOR LEVEL

These details are indicative for the purpose of illustrating the typical installation of M-SERIES panels. Panels are to be installed strictly in accordance with the specifications detailed in the forward section of this manual. Substrate construction to be in accordance with the Building Regulations & Statutory Requirements.

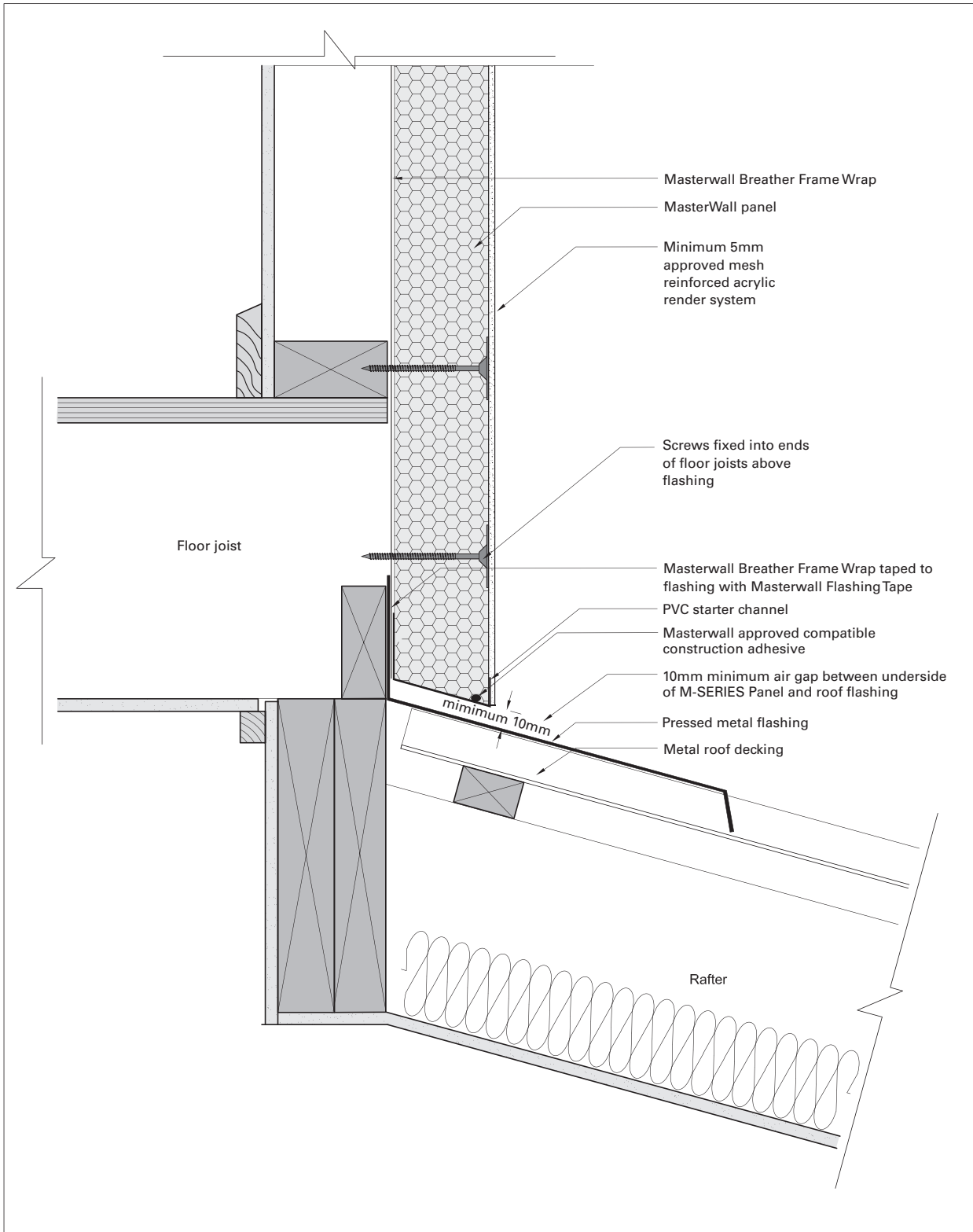

## M-SERIES PANEL: LOWER ROOF JUNCTION - REAR FLASHED

These details are indicative for the purpose of illustrating the typical installation of M-SERIES panels. Panels are to be installed strictly in accordance with the specifications detailed in the forward section of this manual. Substrate construction to be in accordance with the Building Regulations & Statutory Requirements.



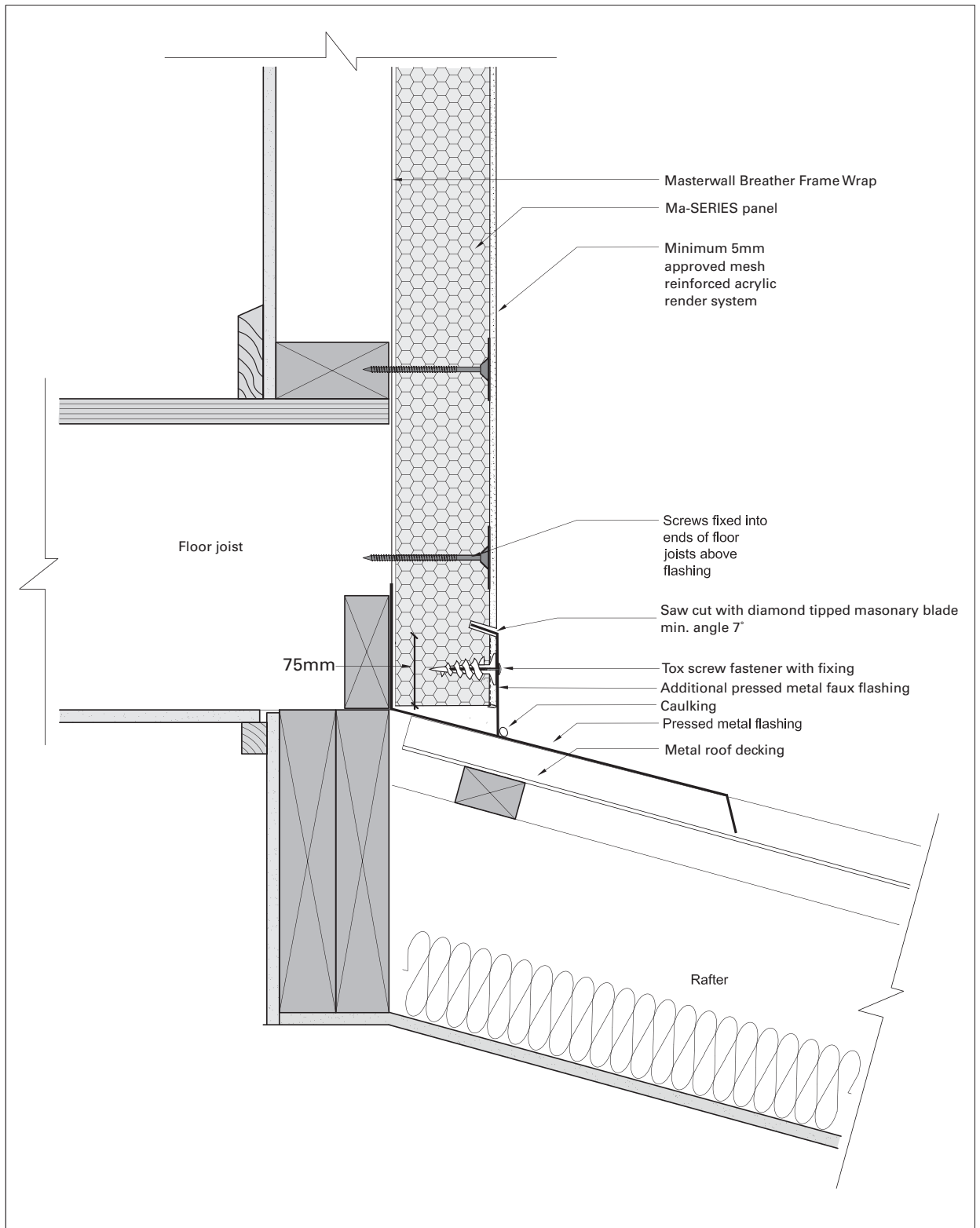

## M-SERIES PANEL: LOWER ROOF JUNCTION WITH ADDITIONAL FAUX FLASHING

These details are indicative for the purpose of illustrating the typical installation of M-SERIES panels. Panels are to be installed strictly in accordance with the specifications detailed in the forward section of this manual. Substrate construction to be in accordance with the Building Regulations & Statutory Requirements.

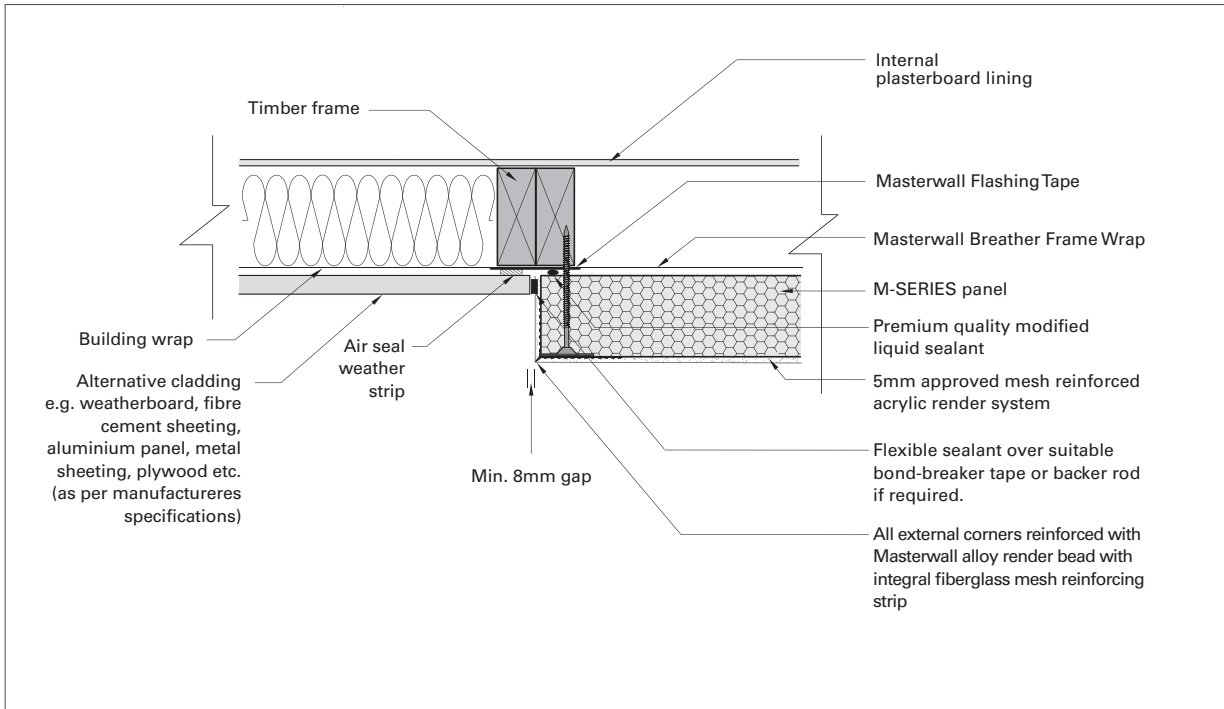

## M-SERIES PANEL: UNIVERSAL JUNCTION

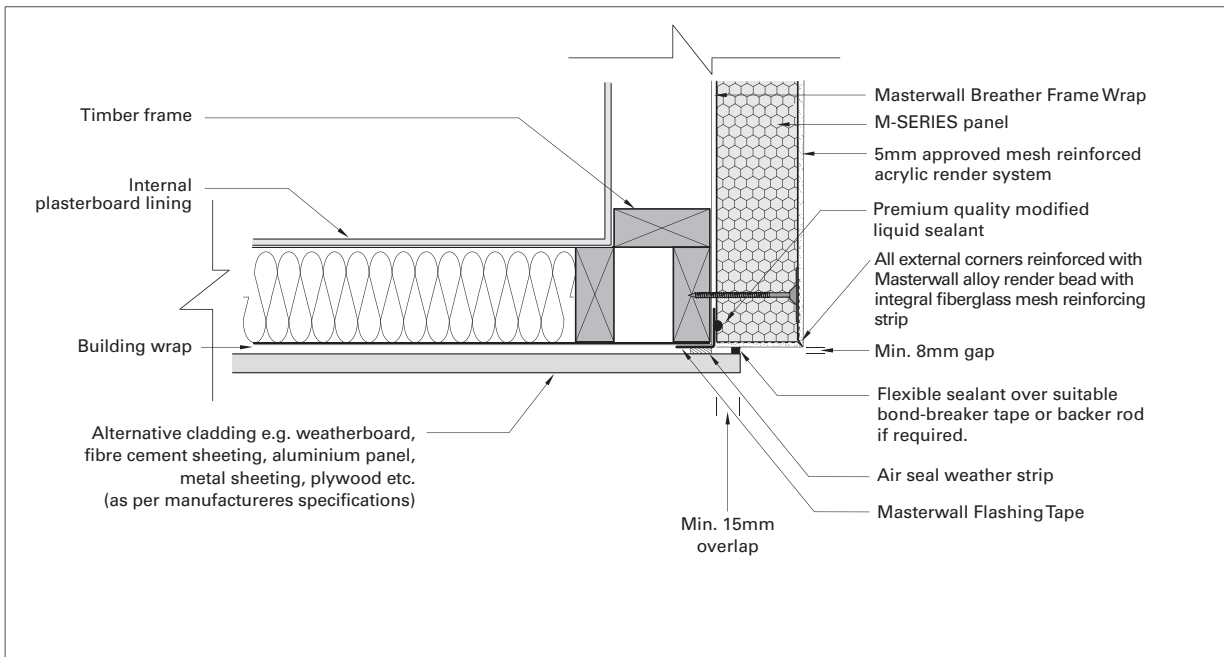

## M-SERIES PANEL / EXTERNAL CORNER: UNIVERSAL JUNCTION

These details are indicative for the purpose of illustrating the typical installation of M-SERIES panels. Panels are to be installed strictly in accordance with the specifications detailed in the forward section of this manual. Substrate construction to be in accordance with the Building Regulations & Statutory Requirements.

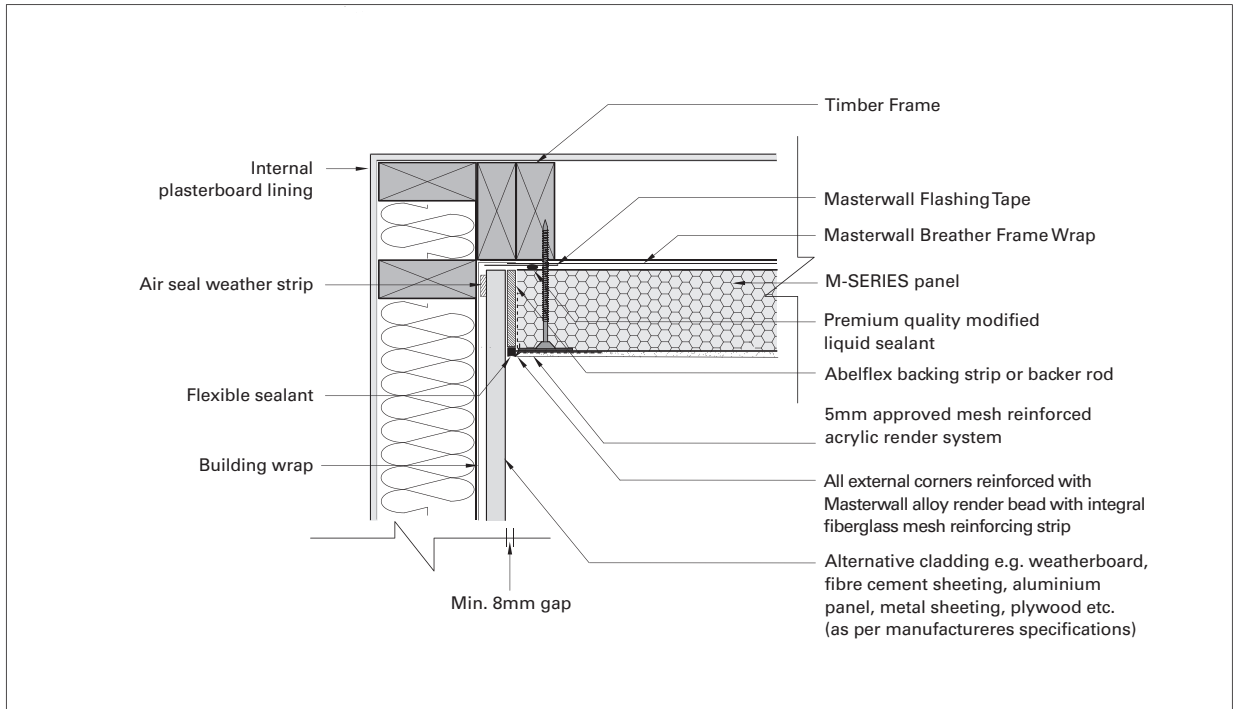

## M-SERIES PANEL / INTERNAL CORNER: UNIVERSAL JUNCTION

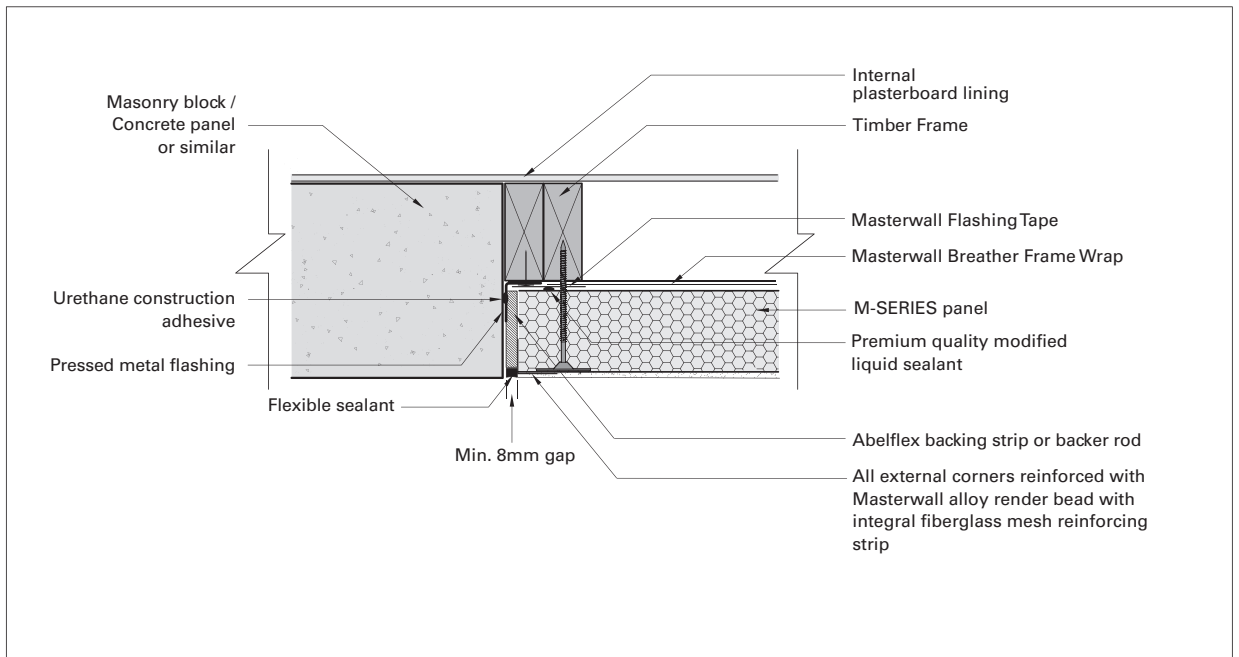

## M-SERIES PANEL / SOLID MASONRY: UNIVERSAL JUNCTION

These details are indicative for the purpose of illustrating the typical installation of M-SERIES panels. Panels are to be installed strictly in accordance with the specifications detailed in the forward section of this manual. Substrate construction to be in accordance with the Building Regulations & Statutory Requirements.

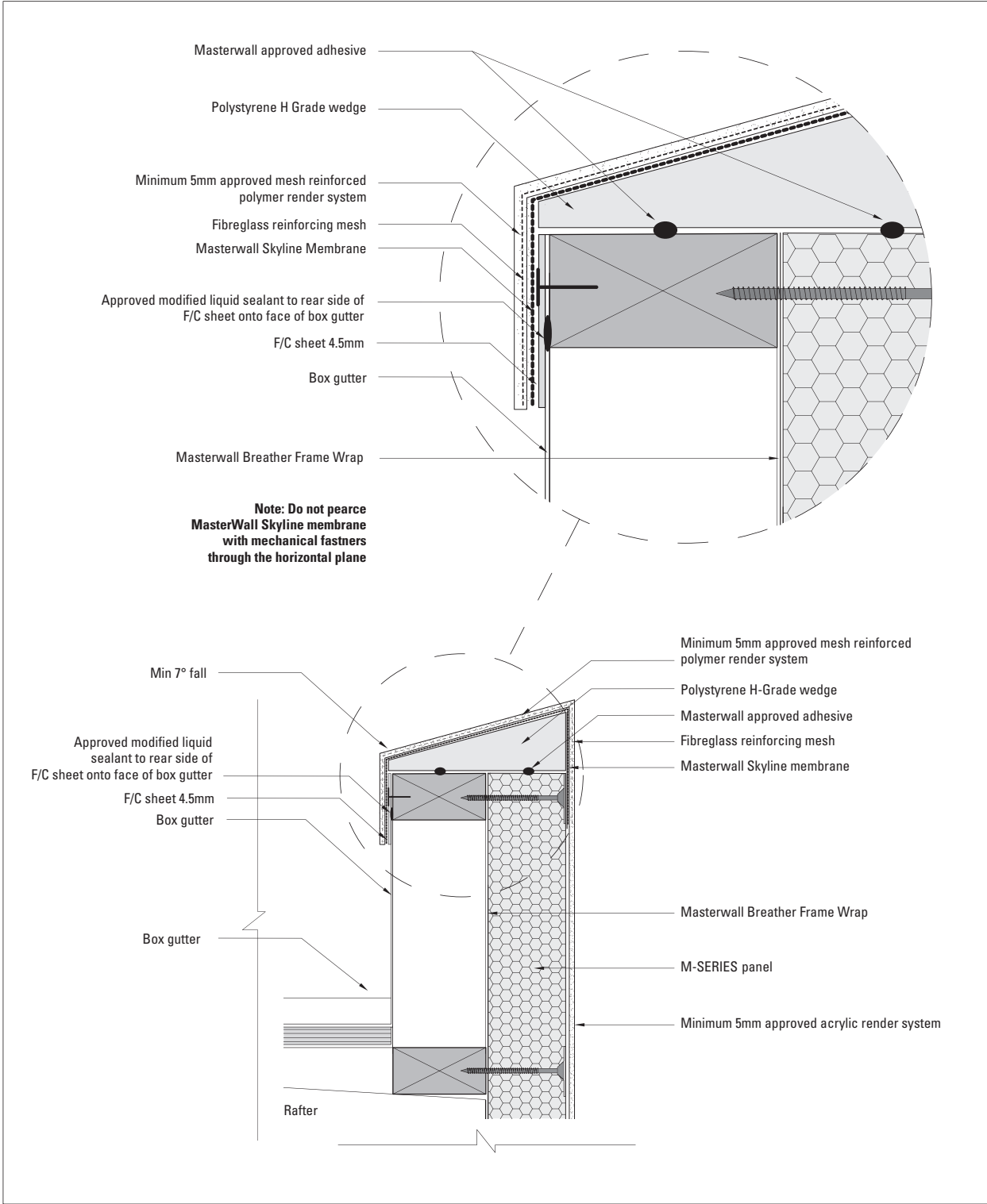

# M-SERIES PANEL: RENDERED PARAPET WALL WITH SKYLINE SYSTEM WATER PROOFING

These details are indicative for the purpose of illustrating the typical installation of M-SERIES panels. Panels are to be installed strictly in accordance with the specifications detailed in the forward section of this manual. Substrate construction to be in accordance with the Building Regulations & Statutory Requirements.

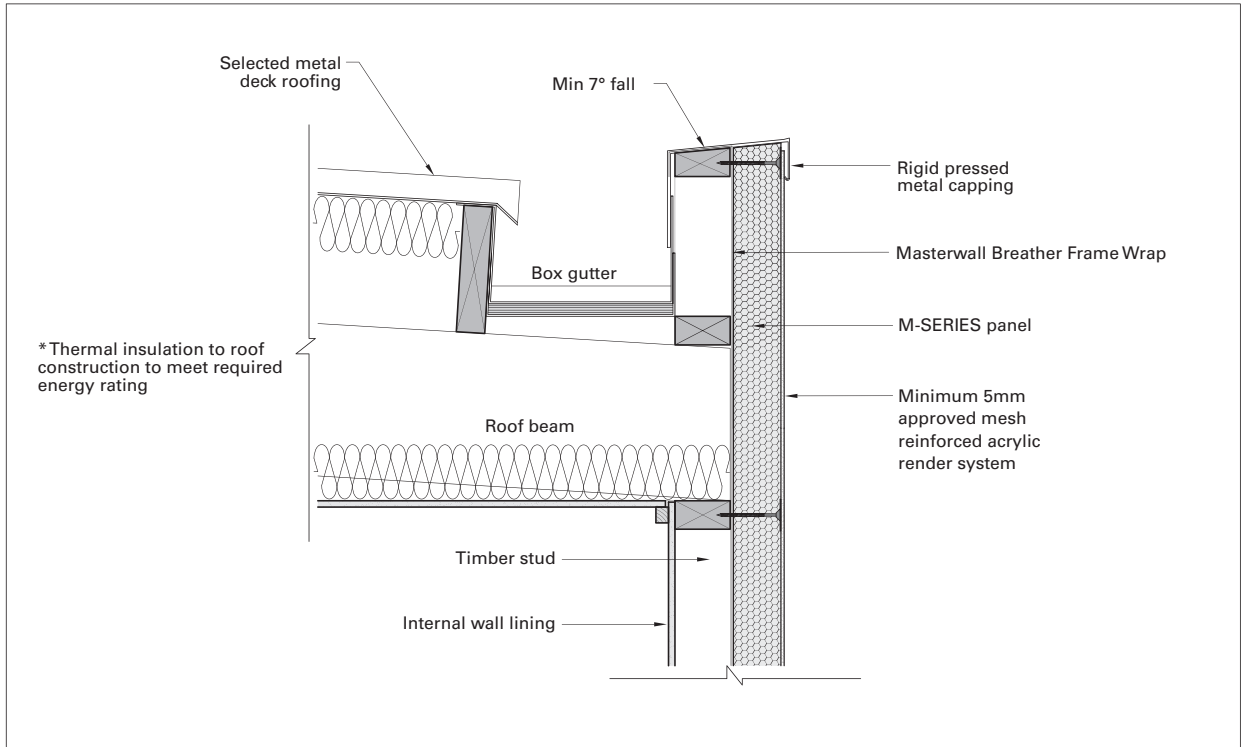

**M-SERIES PANEL / ROOF JUNCTION:  
PARAPET WALL**

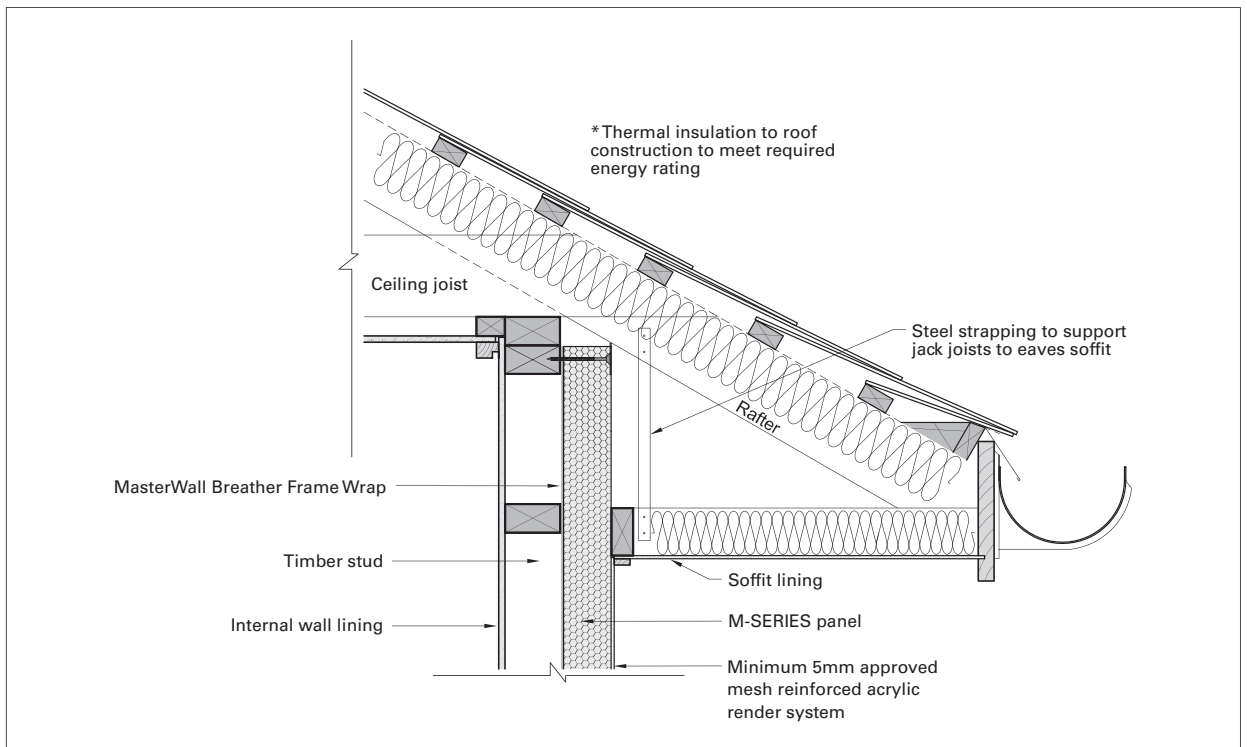

**M-SERIES PANEL / ROOF JUNCTION:  
PITCHED ROOF WITH SOFFIT LINING**

These details are indicative for the purpose of illustrating the typical installation of M-SERIES panels. Panels are to be installed strictly in accordance with the specifications detailed in the forward section of this manual. Substrate construction to be in accordance with the Building Regulations & Statutory Requirements.

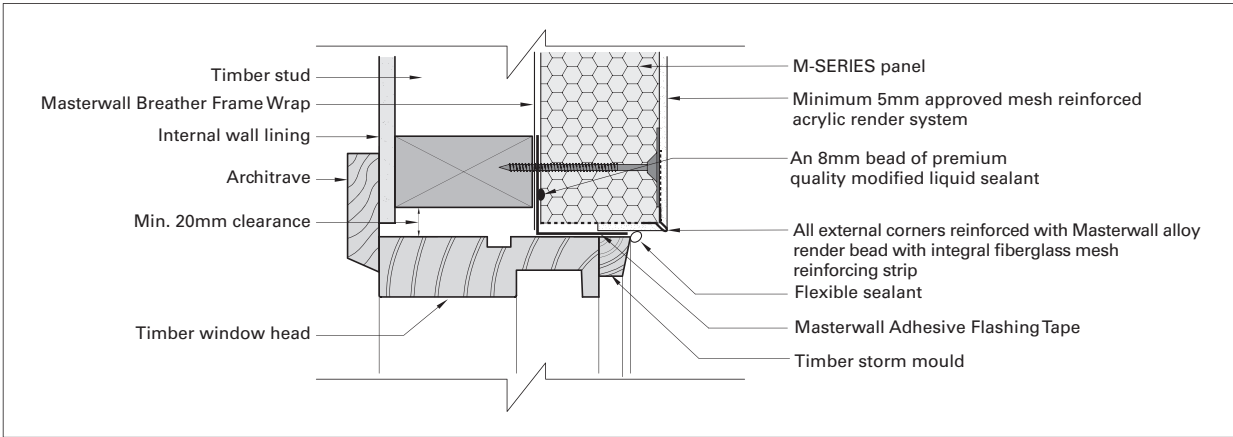

**M-SERIES PANEL / TIMBER WINDOW:  
TYPICAL HEAD DETAIL**

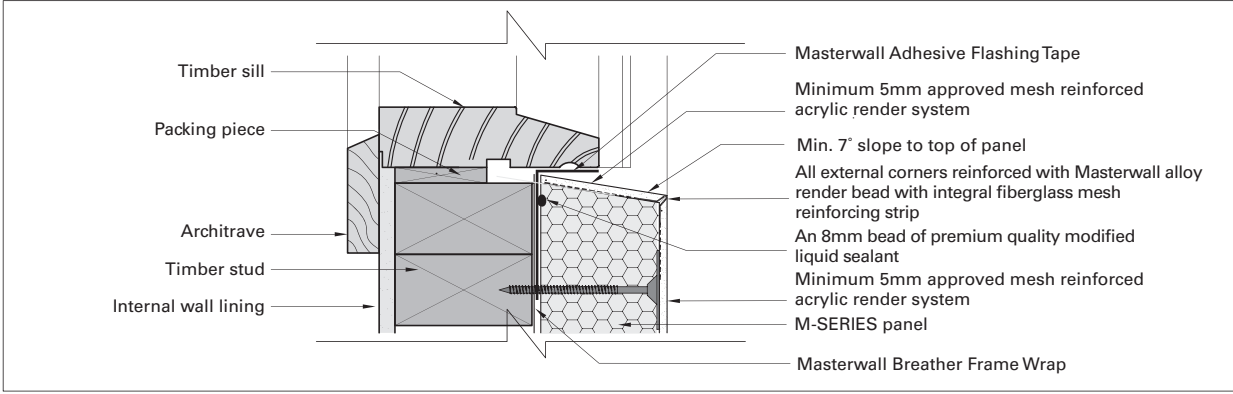

**M-SERIES PANEL / TIMBER WINDOW:  
TYPICAL SILL DETAIL**

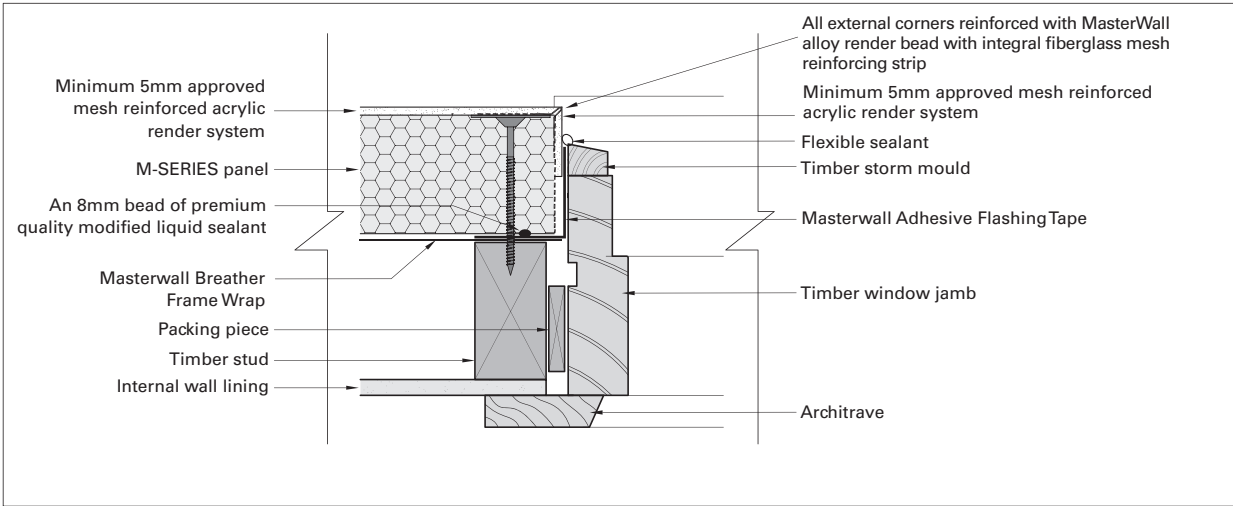

**M-SERIES PANEL / TIMBER WINDOW:  
TYPICAL SIDE JAMB DETAIL**

These details are indicative for the purpose of illustrating the typical installation of M-SERIES panels. Panels are to be installed strictly in accordance with the specifications detailed in the forward section of this manual. Substrate construction to be in accordance with the Building Regulations & Statutory Requirements.

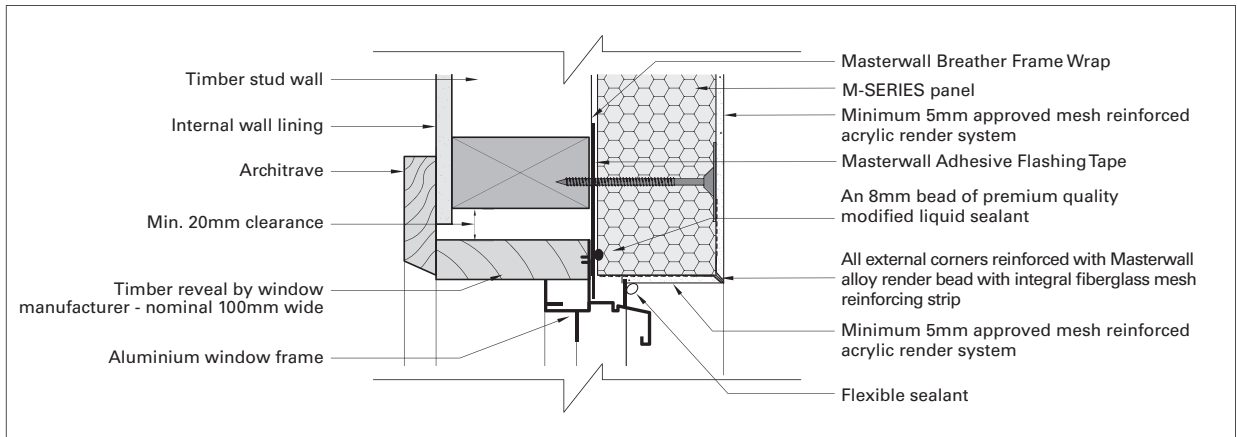

## M-SERIES PANEL / ALUMINIUM WINDOW: TYPICAL HEAD DETAIL

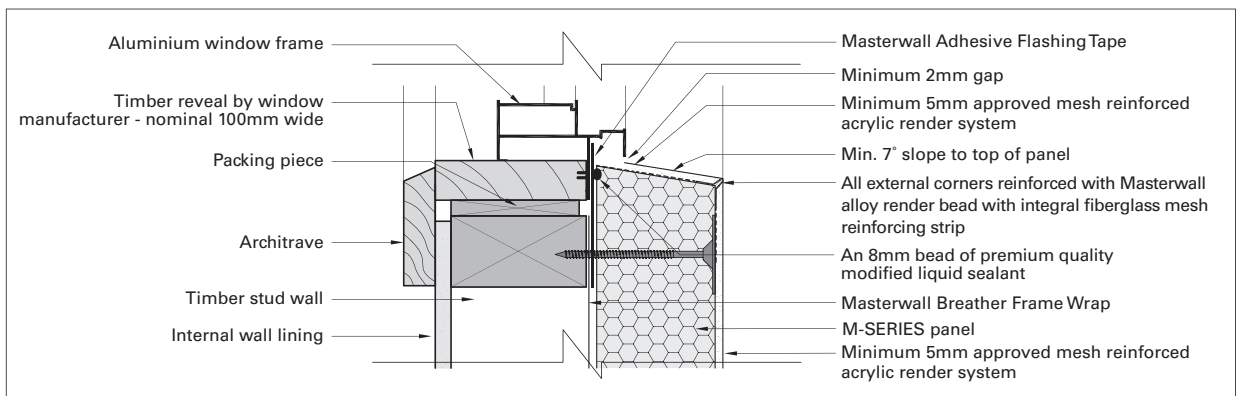

## M-SERIES PANEL / ALUMINIUM WINDOW: TYPICAL SILL DETAIL

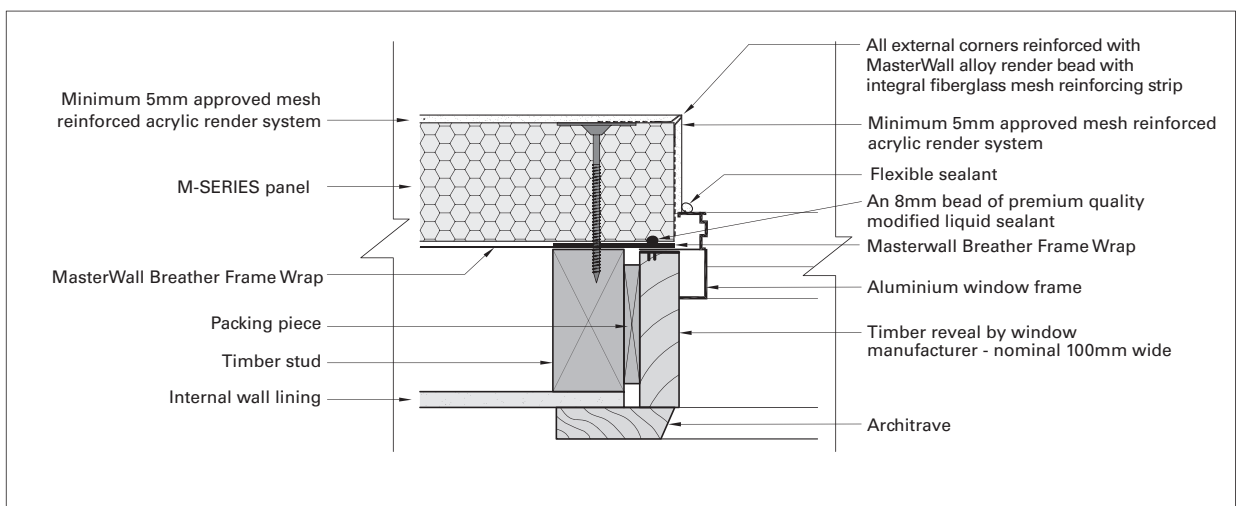

## M-SERIES PANEL / ALUMINIUM WINDOW: TYPICAL SIDE JAMB DETAIL

Note: Window system to be self draining.

These details are indicative for the purpose of illustrating the typical installation of M-SERIES panels. Panels are to be installed strictly in accordance with the specifications detailed in the forward section of this manual. Substrate construction to be in accordance with the Building Regulations & Statutory Requirements.

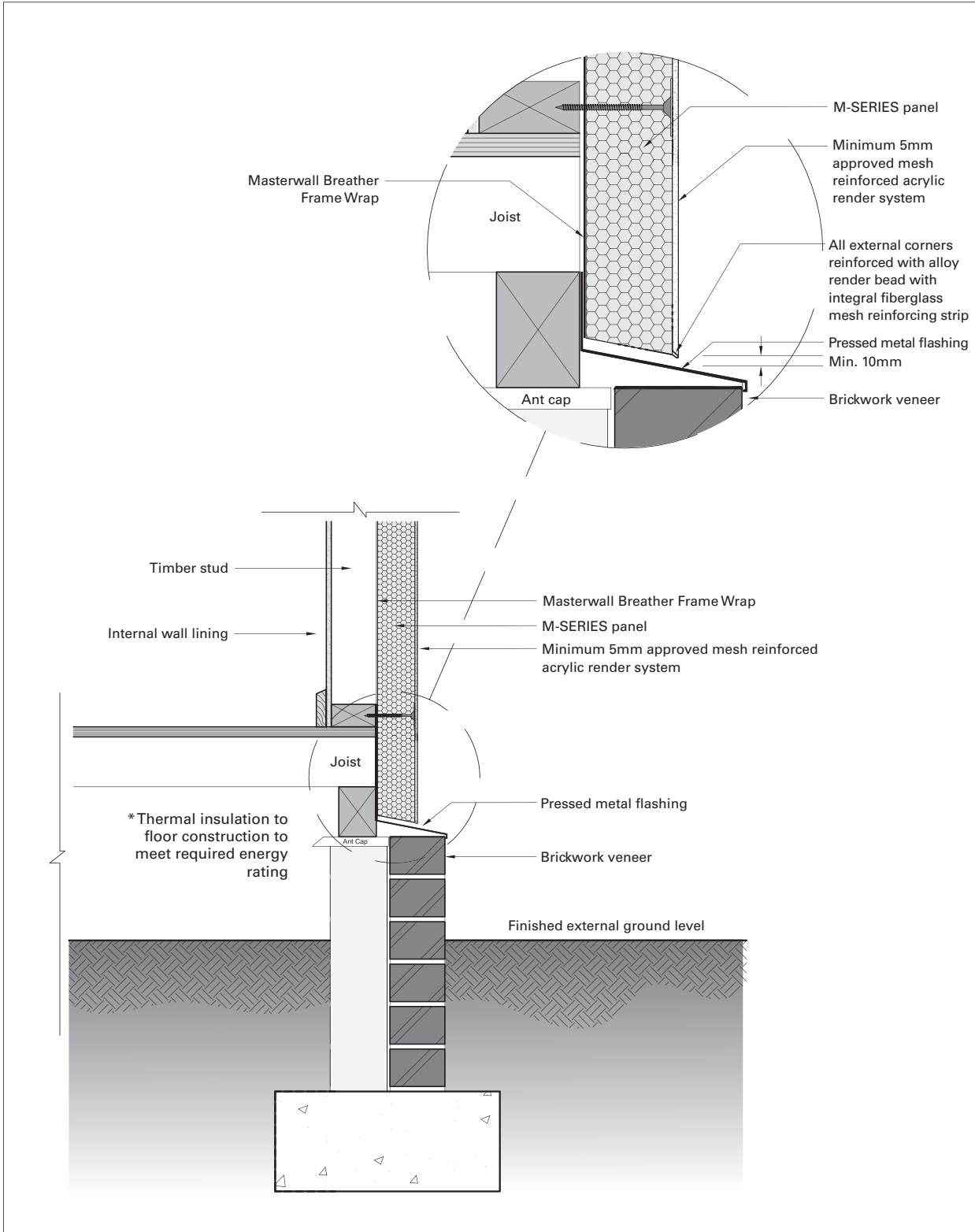

## M-SERIES PANEL & BRICKWORK JUNCTION: GROUND LEVEL

These details are indicative for the purpose of illustrating the typical installation of M-SERIES panels. Panels are to be installed strictly in accordance with the specifications detailed in the forward section of this manual. Substrate construction to be in accordance with the Building Regulations & Statutory Requirements.



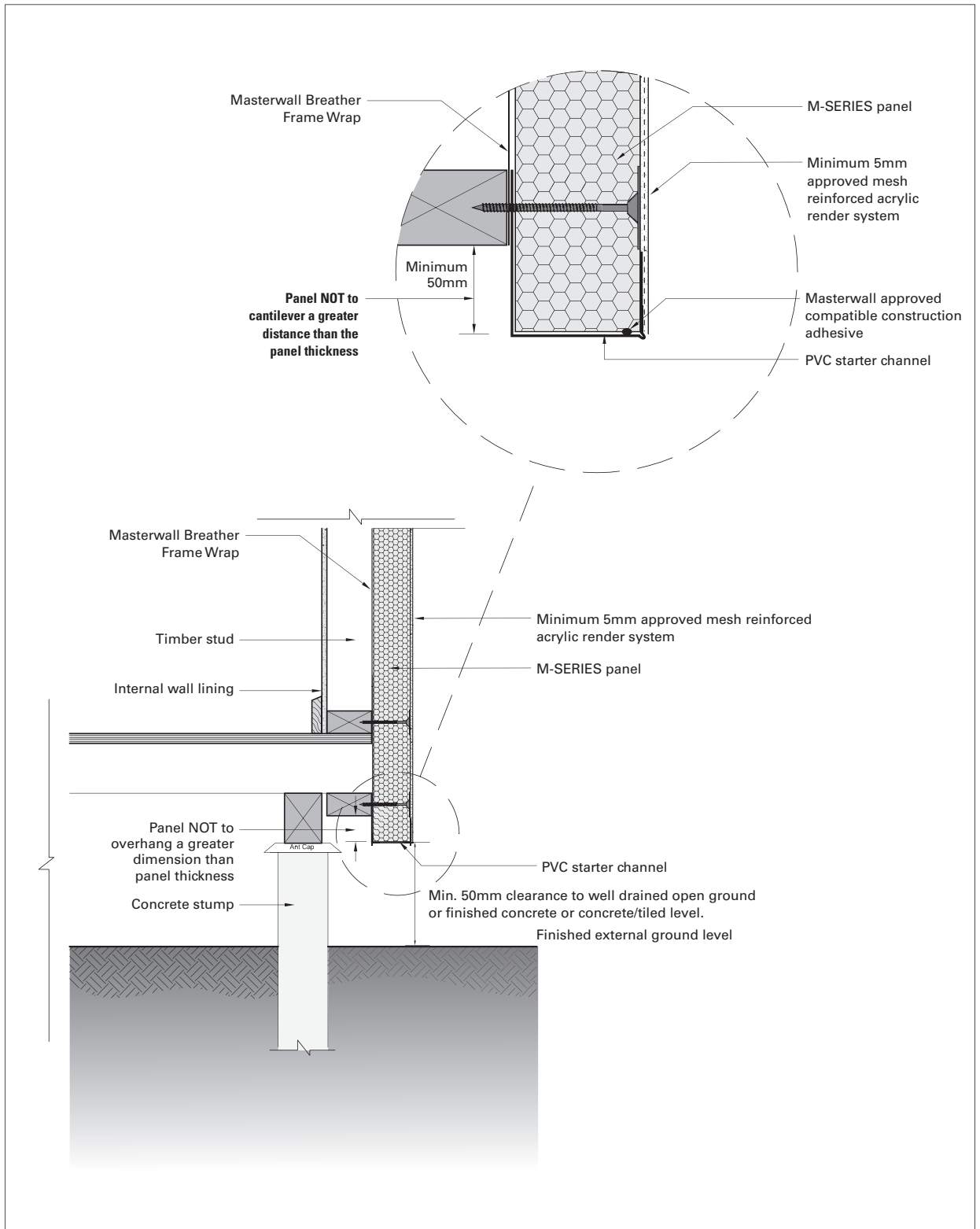

## M-SERIES PANEL & CONCRETE STUMP CONSTRUCTION: PROTRUDING PANEL

These details are indicative for the purpose of illustrating the typical installation of M-SERIES panels. Panels are to be installed strictly in accordance with the specifications detailed in the forward section of this manual. Substrate construction to be in accordance with the Building Regulations & Statutory Requirements.

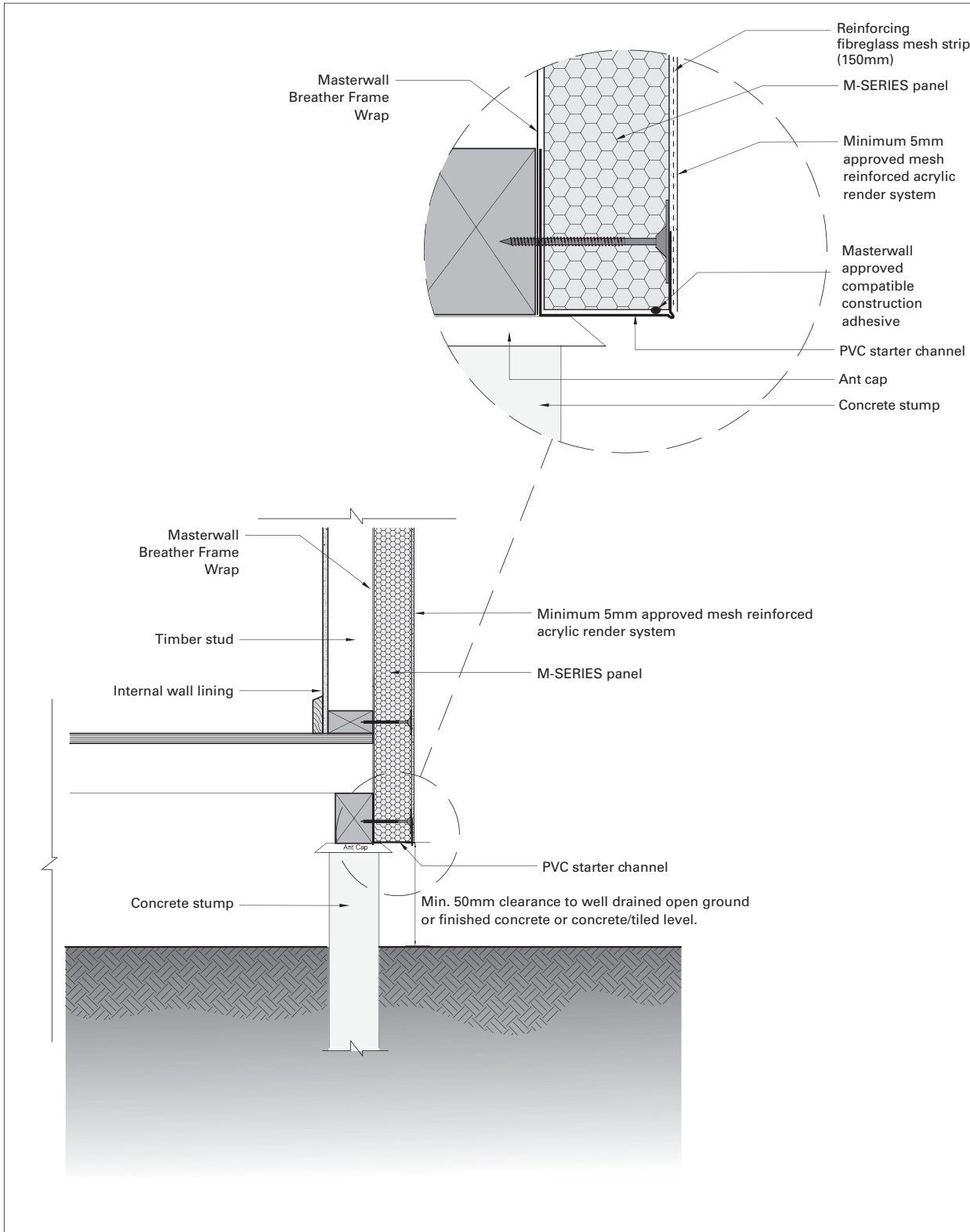

## M-SERIES PANEL & CONCRETE STUMP CONSTRUCTION

These details are indicative for the purpose of illustrating the typical installation of M-SERIES panels. Panels are to be installed strictly in accordance with the specifications detailed in the forward section of this manual. Substrate construction to be in accordance with the Building Regulations & Statutory Requirements.

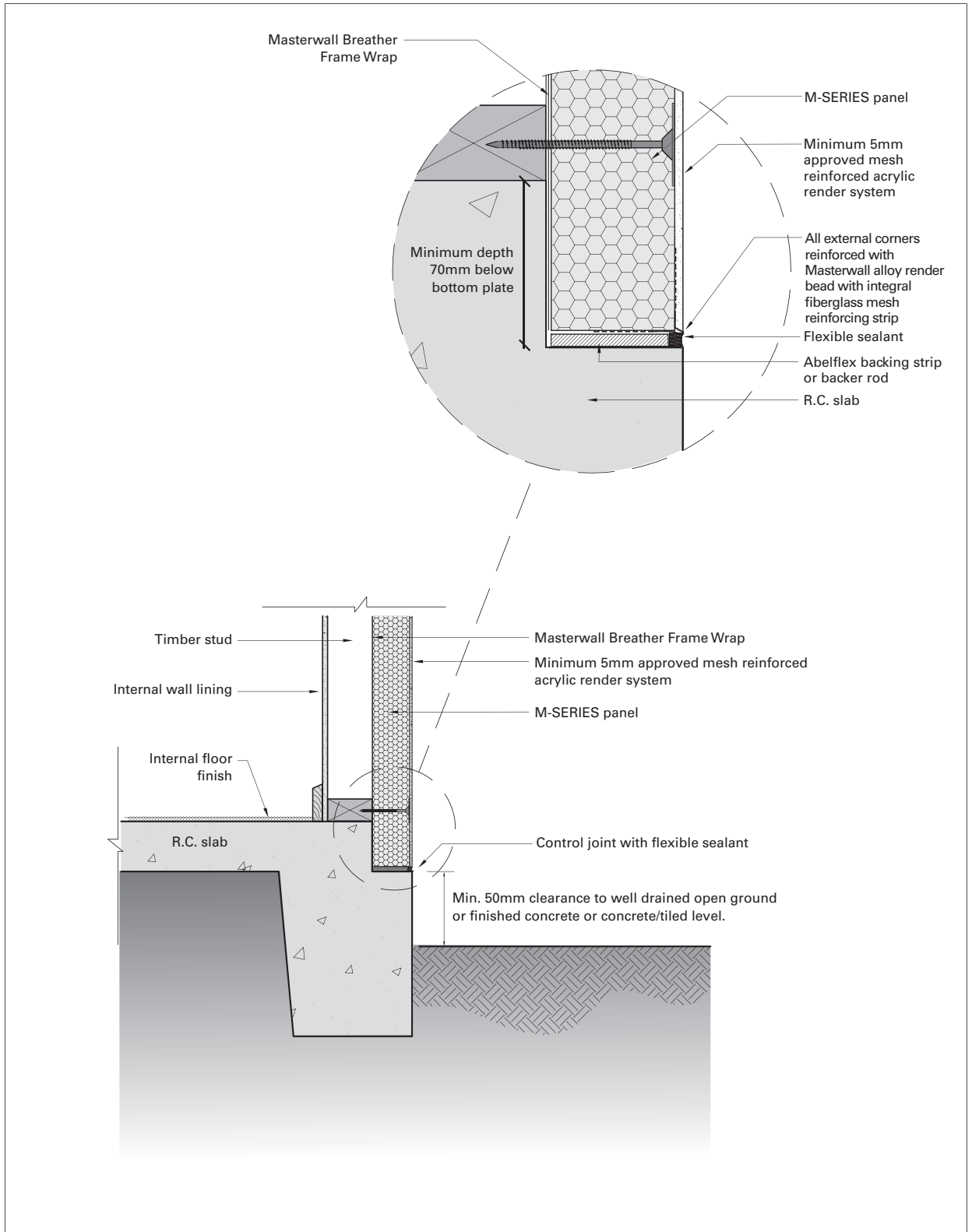

## M-SERIES PANEL & GROUND SLAB JUNCTION WITHIN REBATE

These details are indicative for the purpose of illustrating the typical installation of M-SERIES panels. Panels are to be installed strictly in accordance with the specifications detailed in the forward section of this manual. Substrate construction to be in accordance with the Building Regulations & Statutory Requirements.

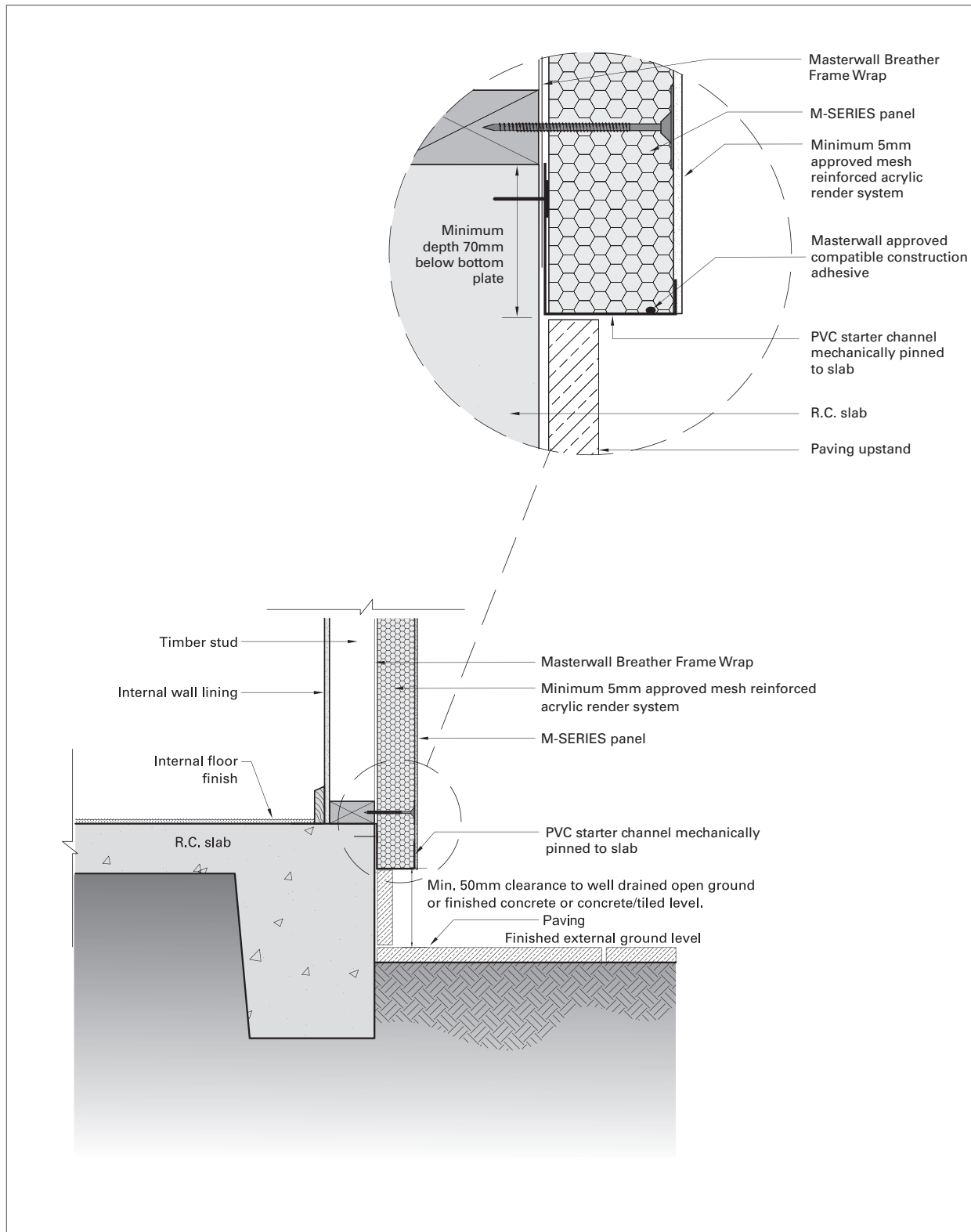

## M-SERIES PANEL & GROUND SLAB JUNCTION PROTRUDING

These details are indicative for the purpose of illustrating the typical installation of M-SERIES panels. Panels are to be installed strictly in accordance with the specifications detailed in the forward section of this manual. Substrate construction to be in accordance with the Building Regulations & Statutory Requirements.

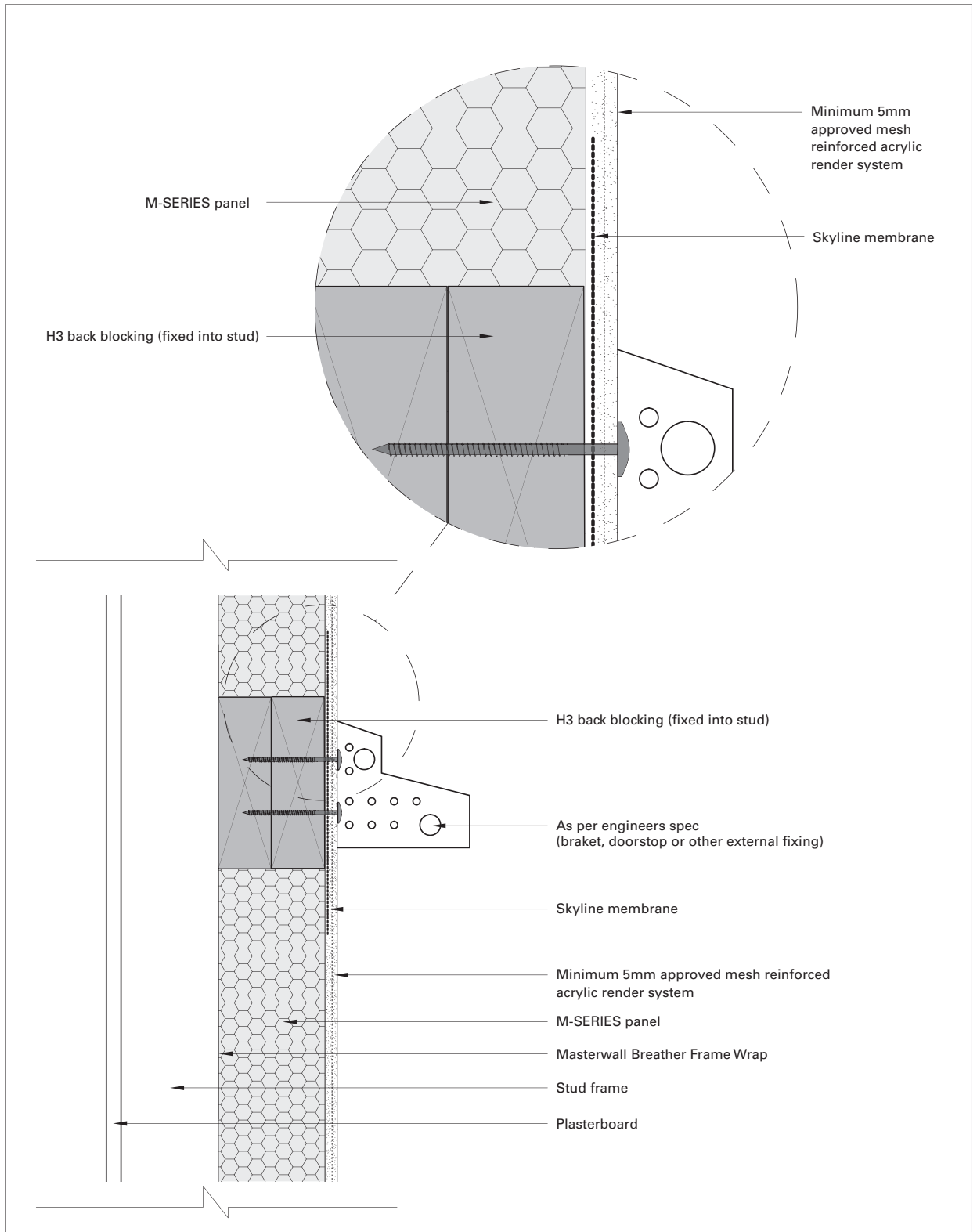

**M-SERIES PANEL / EXTERNAL WALL:  
EXTERNAL SUPPORT WITH SKYLINE SYSTEM  
WATER PROOFING**

These details are indicative for the purpose of illustrating the typical installation of M-SERIES panels. Panels are to be installed strictly in accordance with the specifications detailed in the forward section of this manual. Substrate construction to be in accordance with the Building Regulations & Statutory Requirements.

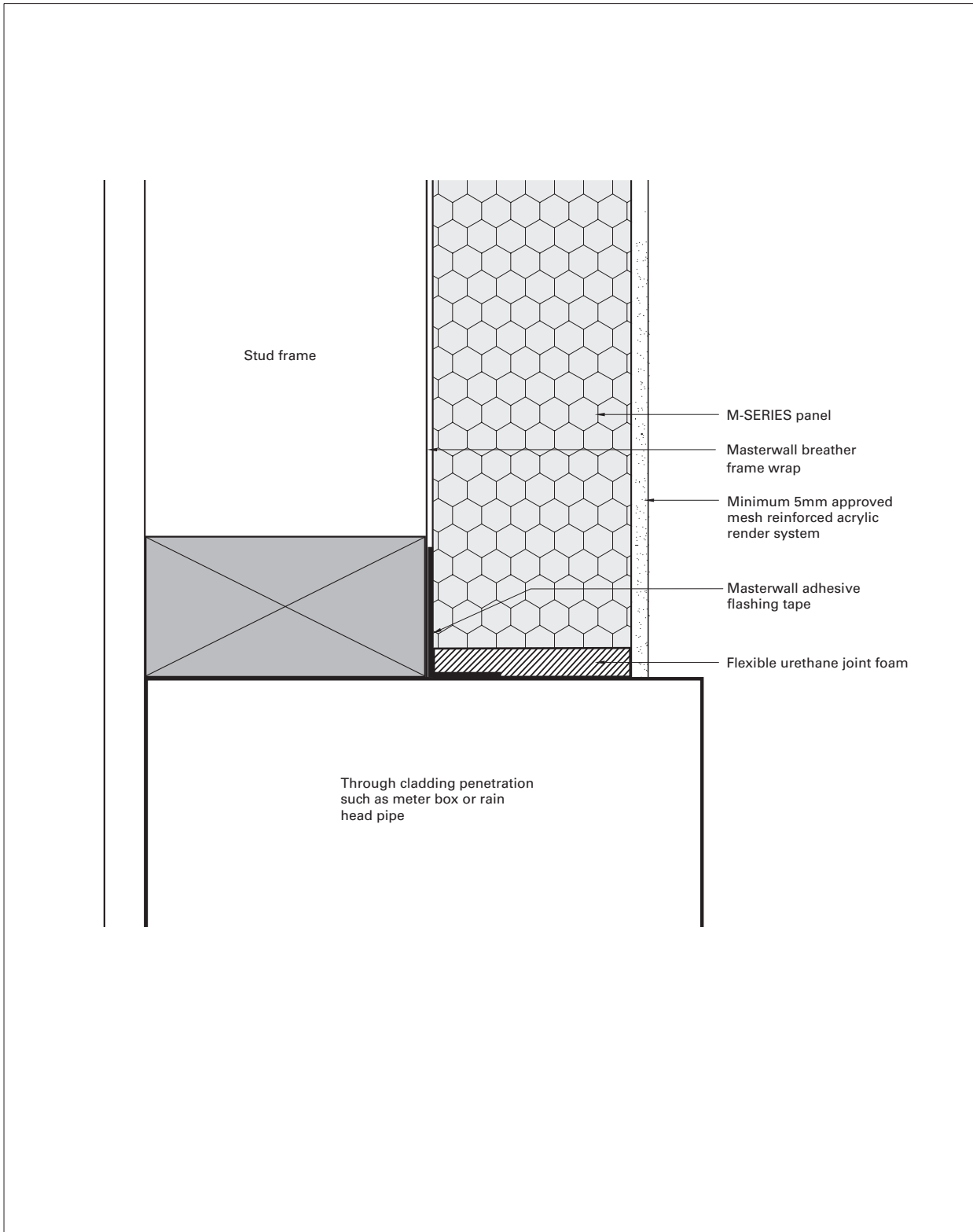

## M-SERIES PANEL: PANEL PENETRATION

These details are indicative for the purpose of illustrating the typical installation of M-SERIES panels. Panels are to be installed strictly in accordance with the specifications detailed in the forward section of this manual. Substrate construction to be in accordance with the Building Regulations & Statutory Requirements.

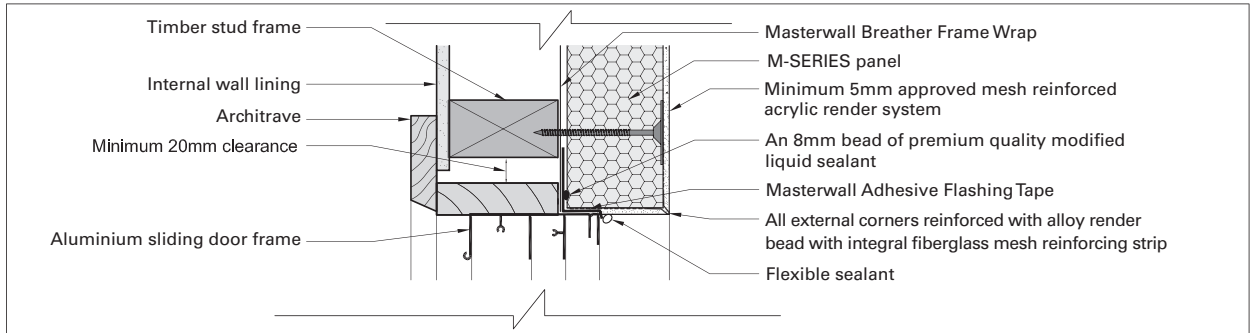

**M-SERIES PANEL / ALUMINIUM SLIDING DOOR - TYPICAL HEAD DETAIL**

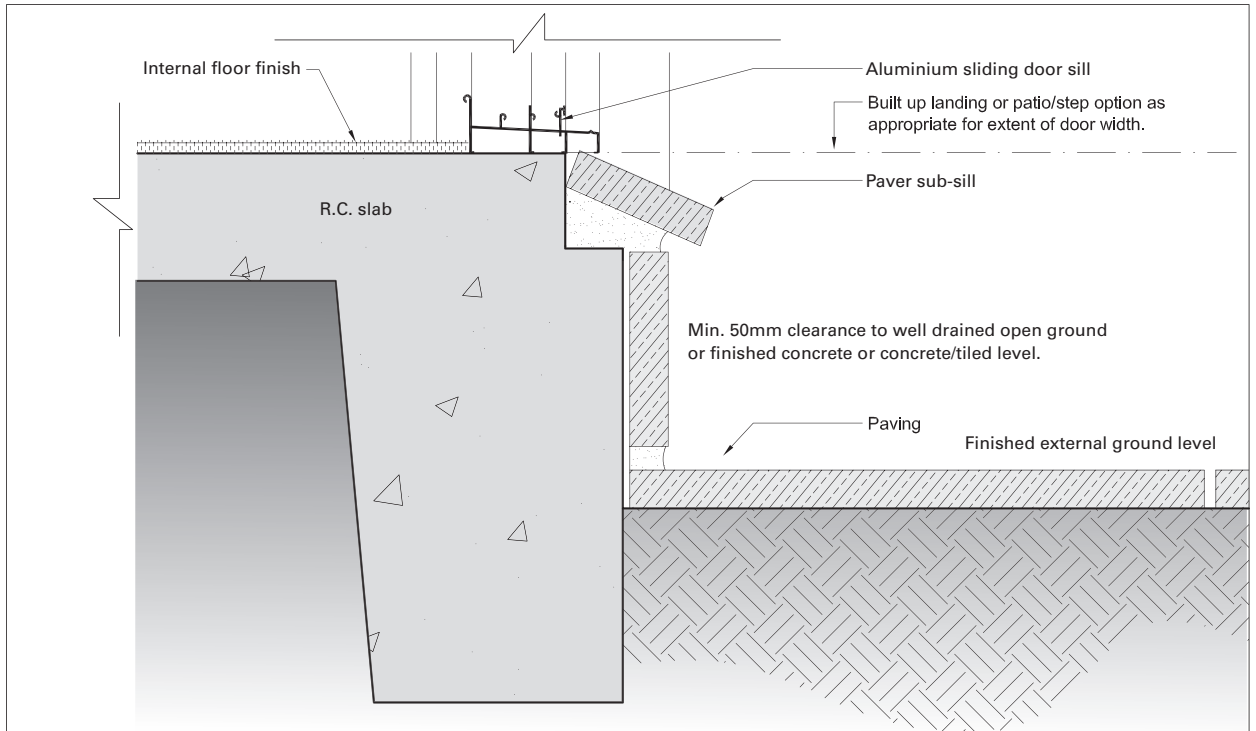

**M-SERIES PANEL / ALUMINIUM SLIDING DOOR - TYPICAL SILL DETAIL**

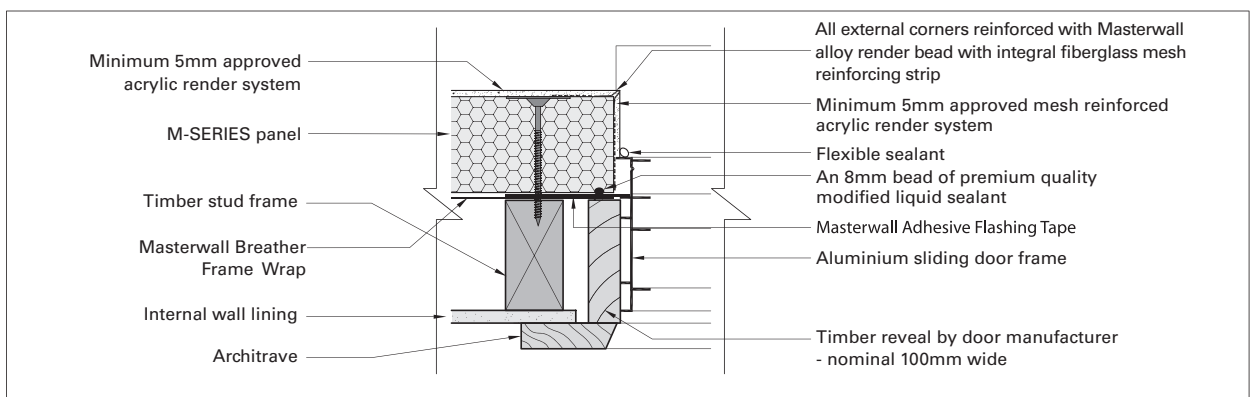

**M-SERIES PANEL / ALUMINIUM SLIDING DOOR - TYPICAL JAMB DETAIL**

These details are indicative for the purpose of illustrating the typical installation of M-SERIES panels. Panels are to be installed strictly in accordance with the specifications detailed in the forward section of this manual. Substrate construction to be in accordance with the Building Regulations & Statutory Requirements.

# 50, 75, 100 & 125mm M-SERIES

## TYPICAL FIXING SUPPORT FOR DOWN PIPE:

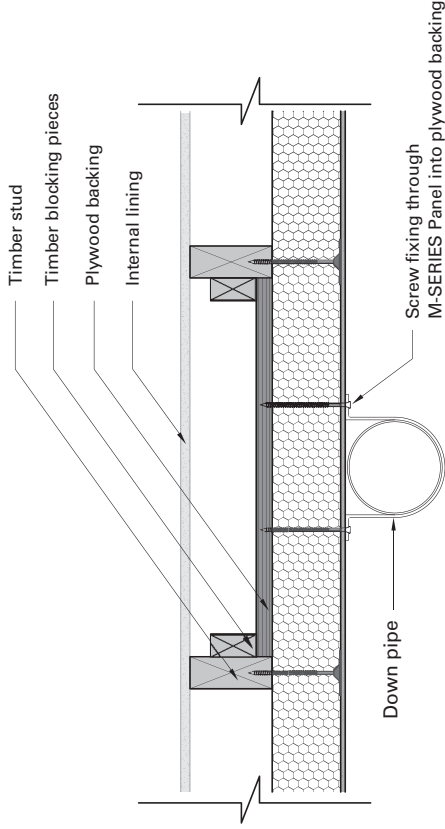
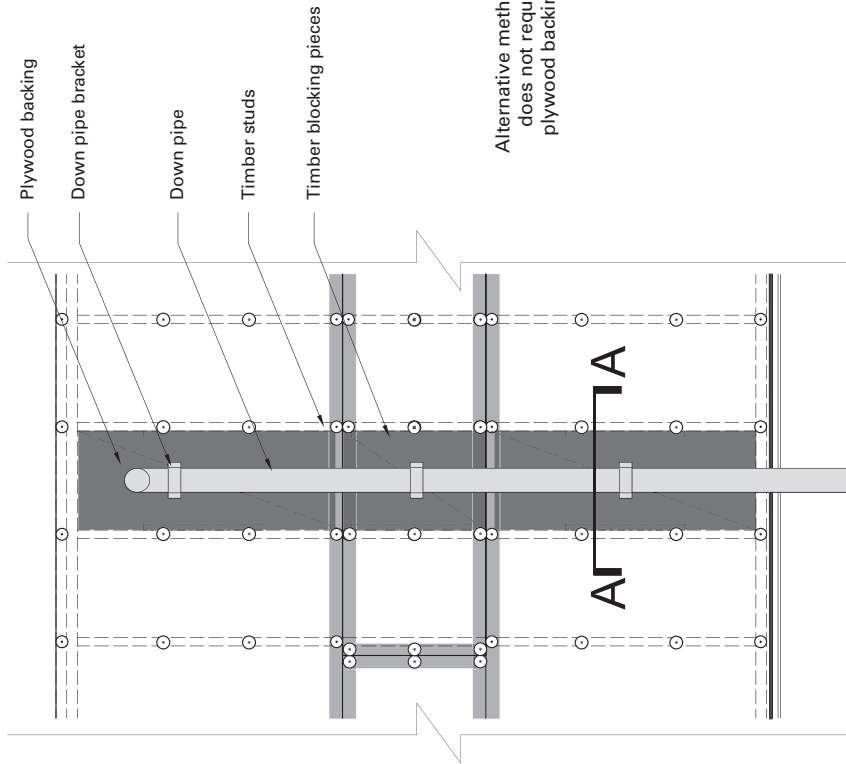

DOWN PIPE - SECTION VIEW A`A

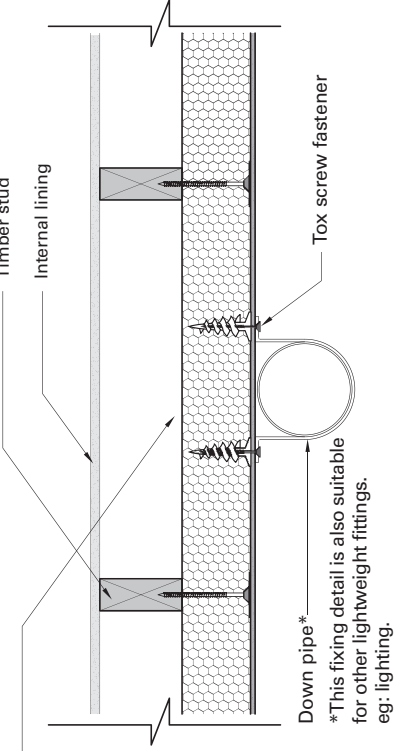

Alternative method does not require plywood backing.

DOWN PIPE - ELEVATION VIEW

DOWN PIPE - ALTERNATIVE USING TOX SCREW FASTENERS

These details are indicative for the purpose of illustrating the typical installation of M-SERIES Panels. Panels are to be installed strictly in accordance with the specifications detailed in the forward section of this manual. Substrate construction to be in accordance with the Building Regulations & Statutory Requirements.





**This page intentionally left blank.**

**This page intentionally left blank.**

## TECHNICAL ADVICE / DESIGN

Masterwall Australia supports all of its products and systems with a comprehensive Technical Advisory Service for specifiers, stockists and contractors.

This includes a software-powered service designed to give fast, accurate technical advice. Simply phone the Masterwall Australia Technical Service Department with your project specifications. Calculations can be carried out to provide a Condensation (Dew Point) Risk Analysis, and/or a Total Wall (RT) System Thermal Value so that the correct insulation thicknesses can be determined for any given project.

## CONTACT MASTERWALL AUSTRALIA

For national Technical and Sales contact Masterwall Australia:

**National phone: (03) 9799 6565**  
**Email: [sales@masterwall.com.au](mailto:sales@masterwall.com.au)**  
**Web: [masterwall.com.au](http://masterwall.com.au)**



Masterwall manufactures and distributes high performance exterior insulation, render and coating systems.

